

KSH

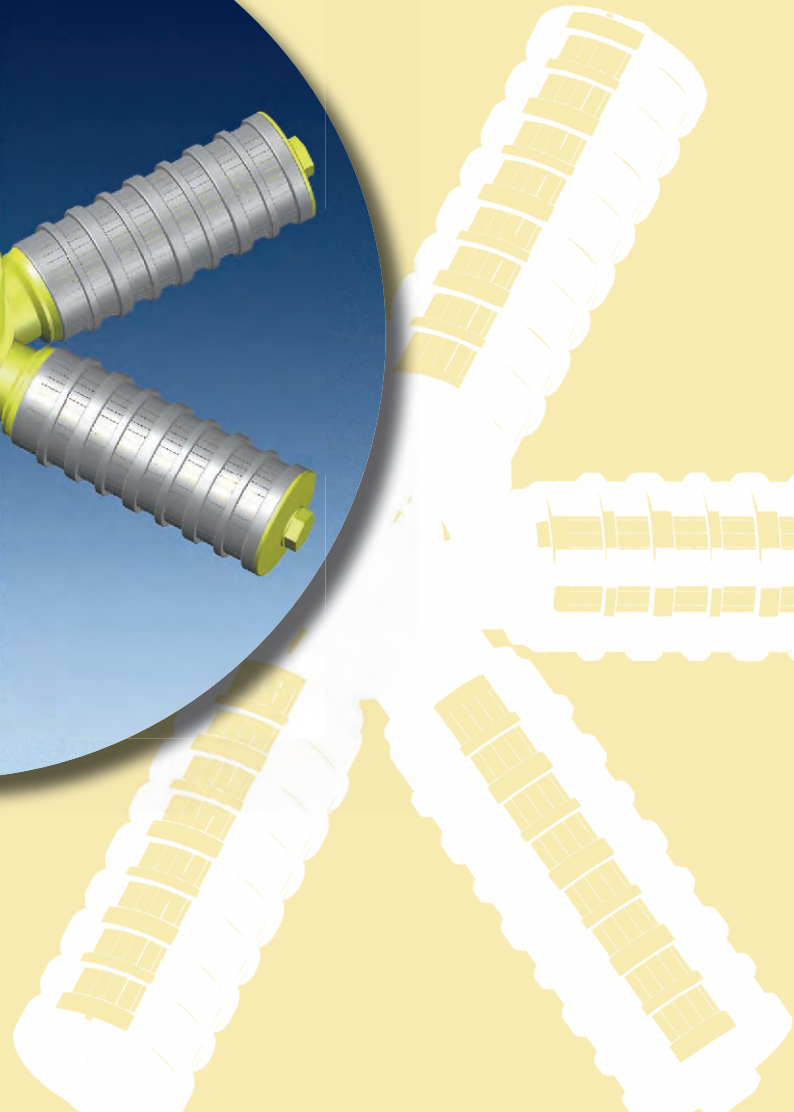

DIN EN ISO 9001-2008

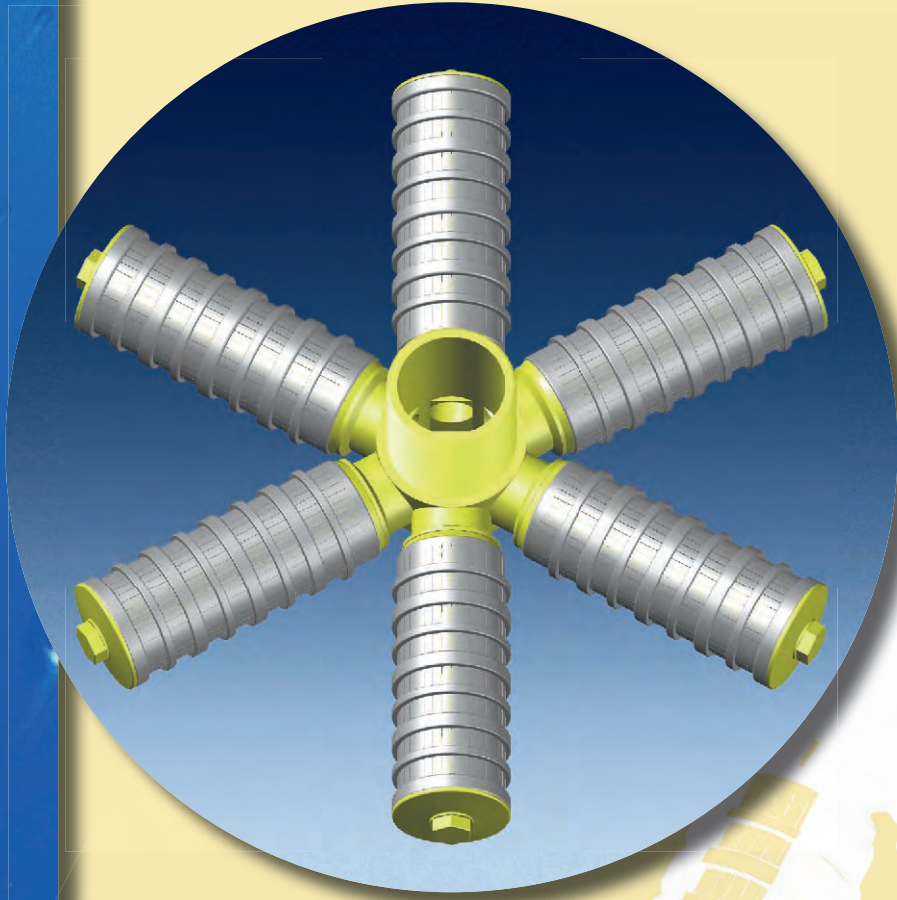

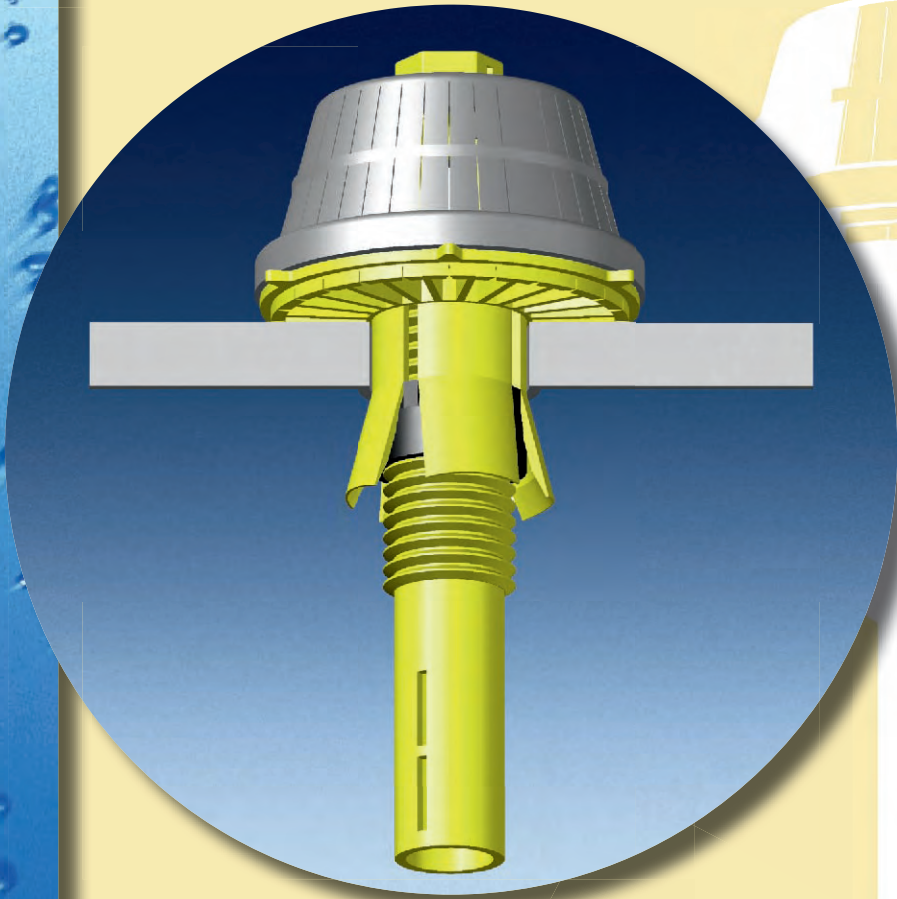

Filterdüsen

Für Wasser und Abwasser-
Aufbereitung

Filter-Nozzles

For water processing and water
cleaning

Crépines à filtre

Pour le traitement et
la filtration de l'eau

Toberas filtrantes

Para el tratamieto y la
filtration del agua



Filterdüsen-Sterne

Filter-Nozzles-Stars

Crépines étoiles

Estrellas para toberas a filtro

Material- beständigkeit	Constancy of the material	Résistance du matériel	Resistencia del Material
Unsere Filterdüsen und Filterdüsensterne werden aus Polypropylen hergestellt. Polypropylen (PP) ist in Abhängigkeit vom Druck zum Beispiel beständig bei 60°C (333 K) gegen:	Our Filter nozzles and Filter nozzles-stars are made of polypropylene. Depending on the drop in pressure for example at 60°C (333 K) Polypropylene (PP) is resistant against:	Nos crépines à filtre sont fabriquées en polypropylène. Le polypropylène (PP) résiste, en fonction de la pression, par exemple à 60°C (333 K) aux produits suivants:	Nuestras toberas y estrellas filtrantes están fabricadas en polipropileno (PP). Dependiendo de la presión puntual de entrada y por ejemplo a 60°C (333 K), el polipropileno es resistente a:
Ammoniak w 10 % Formaldehyd w 10 % Isopropanol w jede Methanol w 50 % Natronlauge 50 % Salzsäure 50 % Schwefelsäure 50 % Sodawasser Ozon 20°C, 50 pphm (0,5mg/L)	ammonia ag 10 % formaldehyde ag 10 % isopropanol all concentrations methanol ag 50 % caustic soda solutions 50 % hydrochloric acid 50 % sulfuric acid 50 % soda water ozone 20°C, 50 pphm (0,5mg/L)	ammoniaque aq 10 % formaldéhyde aq 10 % isopropanol aq toute concentration méthanol aq 50 % solution de soude 50 % acide chlorhydrique 50 % acide sulfurique 50 % eau soda ozone 20°C, 50 pphm (0,5mg/L)	amoniaco, sol. 10 % formaldehído, sol. 10 % isopropanol, cualquier conc. metanol, sol. 50 % sosa cáustica, sol. 50 % ácido clorhídrico, conc. 50 % ácido sulfúrico, conc. 50 % agua de soda Ozono 20°C, 50 pphm (0,5mg/L)
Polypropylen ist physiologisch unbedenklich.	Polypropylene is physiologically unobjectionable.	Le polypropylène est physiologiquement neutre.	El polipropileno es inocuo.
Polypropylen wird bei zunehmenden Frost spröder. Bitte, behandeln Sie Produkte aus PP entsprechend. Bei Kälte empfehlen wir die Filterdüsen und Mutter vor der Montage zu erwärmen.	With increasing frost polypropylene gets more sensitive. Please, handle all articles made of polypropylene accordingly. If it is cold we recommend to warm up filter nozzles and nuts before installation.	Le polypropylène devient plus cassant en cas de gel croissant. Veuillez traiter les produits en polypropylène en tenant compte de ce facteur. Lors de basse température nous recommandons le réchauffement des crépines à filtre ainsi que des écrous avant le montage.	A bajas temperaturas la fragilidad del polipropileno aumenta. Deben utilizarse los productos fabricados en PP, teniendo en cuenta la anterior circunstancia. En caso de bajas temperaturas, recomendamos calienten las toberas filtrantes y tuercas antes de su montaje.
Für Heißwasser bis max. 110°C empfehlen wir in Abhängigkeit vom Druck Polypropylen mit chemisch gekoppelter Glasfaser PPGV. Mit dem Einsatz von PPGV ändern sich die angegebenen Maße. Bitte bei Bedarf nachfragen.	For hot water of a continuous temperature of up to max. 110°C depending on the drop in pressure we recommend polypropylene with chemically combined glass fibres. Using PPGV, the indicated measurements may change. If required, please contact us for information.	Pour de l'eau chaude à température constante allant jusqu'à 110°C max., nous recommandons l'utilisation du polypropylène chargé de fibres de verre. Pour le PPGV, Les dimensions indiquées peuvent changer. Les cas échéant, n'hésitez Pas à nous contacter pour plus d'informations.	Para agua caliente a temperatura constante hasta un máx. de 110°C, y dependiendo de la presión puntual de entrada, recomendamos utilizar nuestras toberas fabricadas en PP reforzadas con de fibra de vidrio. Utilizando PPGV, las medidas indicadas pueden variar. En caso necesario, les pedimos que contacten con nosotros para especificaciones.
Für Heißwasser bis max. 135°C empfehlen wir in Abhängigkeit vom Druck PVDF. (Bedingt beständig gegen konzentrierte Laugen).	For hot water of a continuous temperature of up to max. 135°C depending on the drop in pressure we recommend PVDF. (Conditionally resistant to concentrated caustic solutions).	Pour de l'eau chaude à température constante allant jusqu'à 135°C max., nous recommandons l'utilisation du PVDF (résistance limitée aux solutions concentrées).	Para agua caliente a temperatura constante hasta un máx. de 135°C, dependiendo de la presión puntual de entrada, recomendamos utilizar nuestras toberas fabricadas en PVDF. Resisten soluciones concentradas de bases fuertes (con restricciones).
Farben für Schlitz (PP): 0,2 = elfenbein 0,3 = grün 0,35 = weiß 0,5 = grau 0,7 = gelb 0,8 = blau 1,0 = schwarz 1,5 = orange 2,0 = grün	Colour of slots (PP): 0,2 = ivory 0,3 = green 0,35 = white 0,5 = grey 0,7 = yellow 0,8 = blue 1,0 = black 1,5 = orange 2,0 = green	Coloration par fente (PP): 0,2 = ivoire 0,3 = vert 0,35 = blanc 0,5 = gris 0,7 = jaune 0,8 = bleu 1,0 = noir 1,5 = orange 2,0 = vert	Color de las ranuras (PP): 0,2 = marfil 0,3 = verde 0,35 = blanco 0,5 = gris 0,7 = amarillo 0,8 = azul 1,0 = negro 1,5 = naranja 2,0 = verde
Anzugsmoment siehe Montageanleitungen	Tightening torque see at Installation-instruction	Couple de serrage voir instructions de montage	Par de apriete en el manual de instrucciones
1 mWS = ca. 0,1 bar	1 mWS = approx. 0,1 bar	1 m de colonne d'eau = env. 0,1 bar	1 mWS = aprox. 0,1 bar
Gewinde in Anlehnung an DIN ISO 228 für G, BSP ANSI B1.20.1-1983 für NPT, NPSM ANSI B1.1a-1984 für UN	Threads in the approach of DIN ISO 228 for G, BSP ANSI B1.20.1-1983 for NPT, NPSM ANSI B1.1a-1984 for UN	Les fils dans l'approche de DIN ISO 228 pour G, BSP ANSI B1.20.1-1983 pour NPT, NPSM ANSI B1.1a-1984 pour UN	Número aproximado hilos de rosca según DIN ISO 228 para G, BSP ANSI B1.20.1-1983 para NPT, NPSM ANSI B1.1a-1984 para UN
Maße in mm.	Dimensions in mm.	Dimension en mm.	Dimensiones en mm.
Irrtümer / Druckfehler Technische Änderungen vorbehalten.	Error / Pressure Failure We reserve the right to alter specifications.	Sous réserve de fautes ou d'erreurs d'impression et de modifications techniques.	Error / Fallo de Presión Nos reservamos el derecho de alterar las especificaciones técnicas.
Alle technischen Informationen verstehen sich ohne jede Gewähr. Es gelten die Angaben des jeweils angeforderten Datenblattes.	No responsibility is taken for the correctness of the technical information. Only specifically provided data sheets are valid.	Toutes les informations techniques sont sans garantie. Seules les fiches techniques spécifiquement fournies au client sont valables.	Todos informaciones técnicas son sin garantía. Solamente nuestras hojas de datos específicos directamente transmitidos al cliente son válidos.

Filterdüsen

Filter-Nozzles

Crépines à filtre

Toberas filtrantes

Typ K1 / KR1

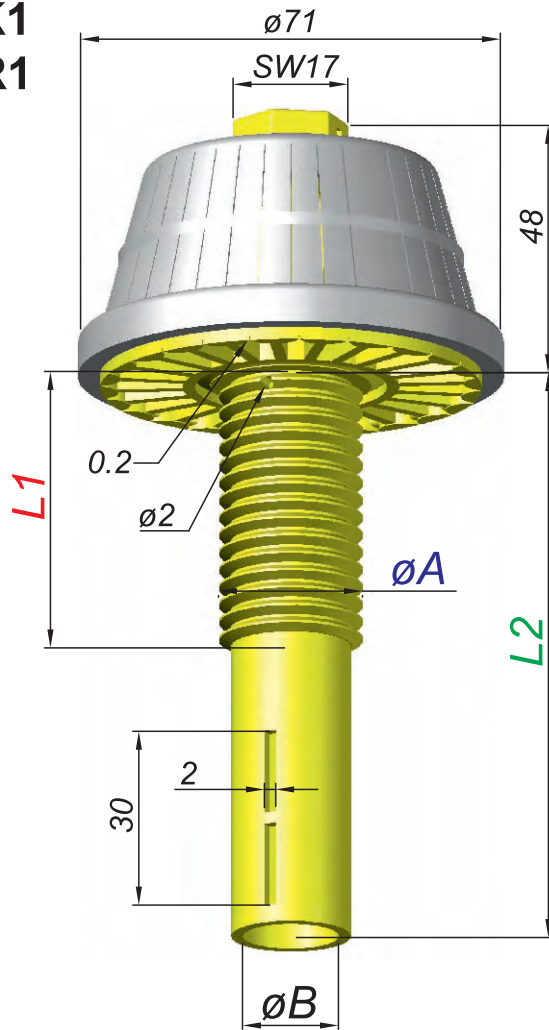

Typ K1

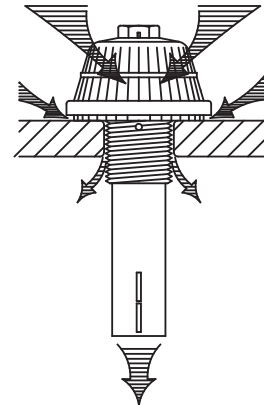

Typ KR1

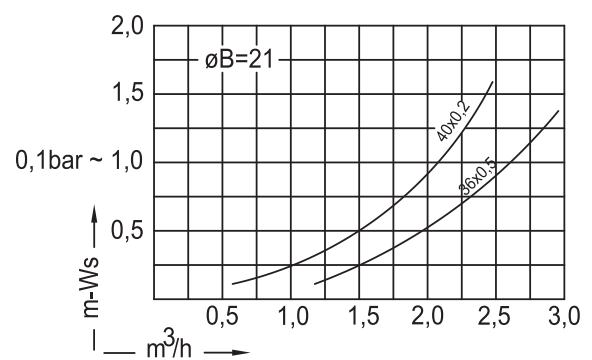
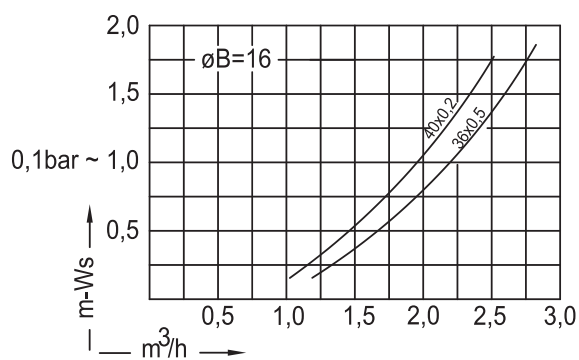
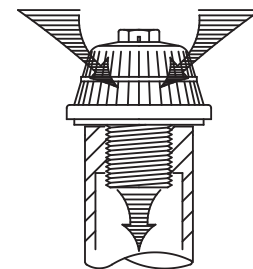

Bestellung Ordering Commande Encargo	Typ Type Type Tipa	Schlitze Slots Fentes Ranuras	Gewinde Thread Filetage Rosca	ϕA	Gewindelänge Thread length Longueur de filetage Largura de la rosca	Schaft Shaft Longueur de tige Tija	ϕB			
✉	K1 KR1	40x0,2 = 1,95 cm ² 36x0,35 = 2,96 cm ² 20x0,5 = 2,35 cm ² 36x0,5 = 4,23 cm ² 20x0,8 = 3,78 cm ² 36x1,0 = 8,46 cm ² 24x1,5 = 7,05 cm ² 20x2,0 = 9,50 cm ²	G1"	33,25	20	80, 110, 140, 200, 250, 300, 350, ...	21 = 3,4 cm ²			
			1 1/4" WW	32	20, 30, 45, +5+5...					
			M30 x 3.5	30	30					
						G3/4"	26,5	20, 30, 45, +5+5...	80, 110, 140, 200, 250, 300, 350, ...	16 = 2,0 cm ²
			1" WW	25,4	20, 45, +5+5...					
			M24	24	25, 45, +5+5...					
						M22 x 1,5	22	45, +5+5...	80, 110, 140, 200, ...	13 = 1,3 cm ²
			G1/2"	21	15, 20, 40					
			M20	20	45, +5+5...					
						G3/8"	16,7	20		

Filterdüsen

Filter-Nozzles

Crépines à filtre

Toberas filtrantes

Typ KSP

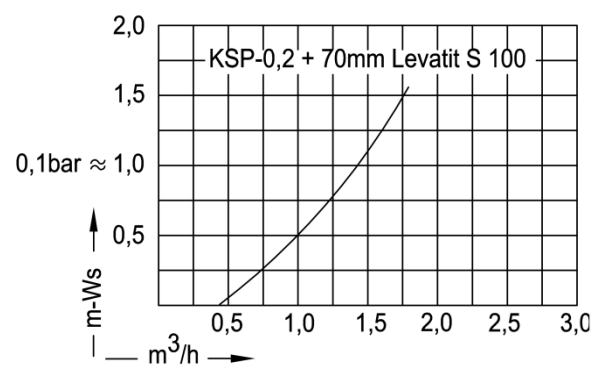
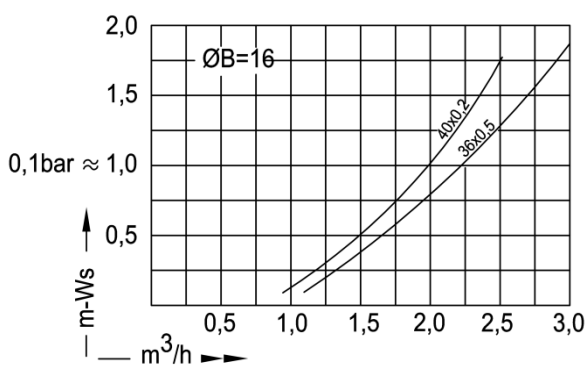
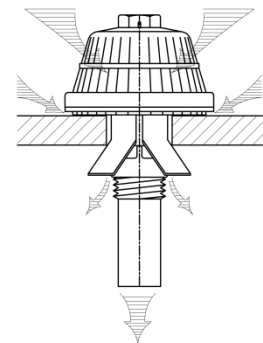
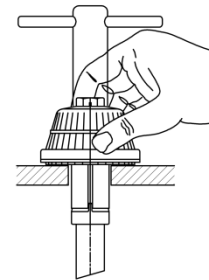
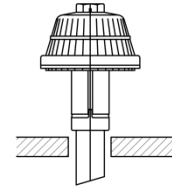
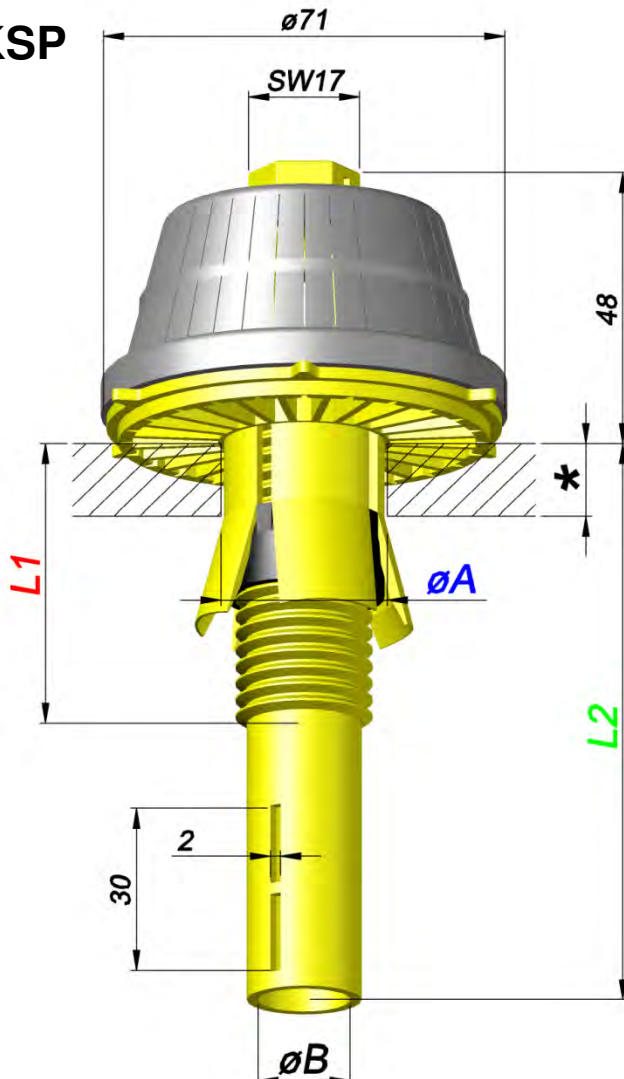

Bestellung Ordering Commande Encargo	Typ Type Type Tipa	Schlitze Slots Fentes Ranuras	*	L1	Schaft Shaft Longueur de tige Tija	L2	øA	øB
✉	KSP	40 x 0,2 = 1,95 cm²	8 - 28	50	80, 110, 140, 200, 250		28-29,5; 29,5-31,5; 31,5-33;	16 = 2,0 cm²
		36 x 0,35 = 2,96 cm²	25 - 45	73	110, 140, 200, 250		33-34,5; 34,5-36;	
		20 x 0,5 = 2,35 cm²						
		36 x 0,5 = 4,23 cm²	8 - 28	50	80, 110, 140, max. 200		25-27,5 ; 26,5-28,5	13 = 1,3 cm²
		20 x 0,8 = 3,78 cm²	25 - 45	73	80, 110, 140, max. 200			
		36 x 1,0 = 8,46 cm²						
24 x 1,5 = 7,05 cm²								
		20 x 2,0 = 9,50 cm²						

Filterdüsen

Filter-Nozzles

Crépines à filtre

Toberas filtrantes

Typ D

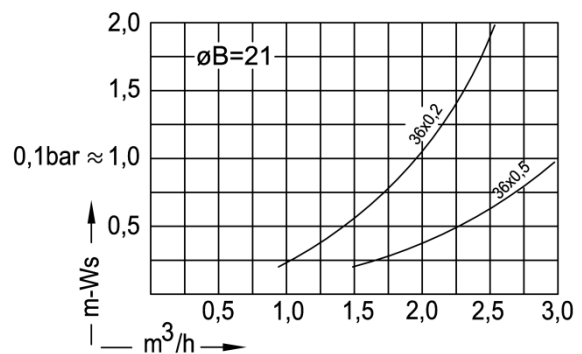
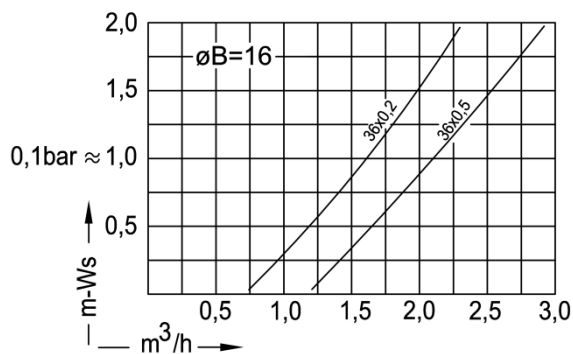
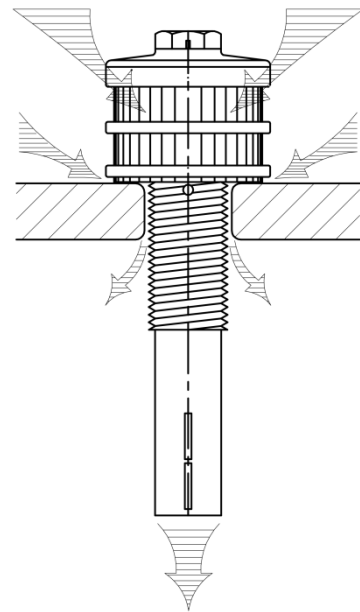
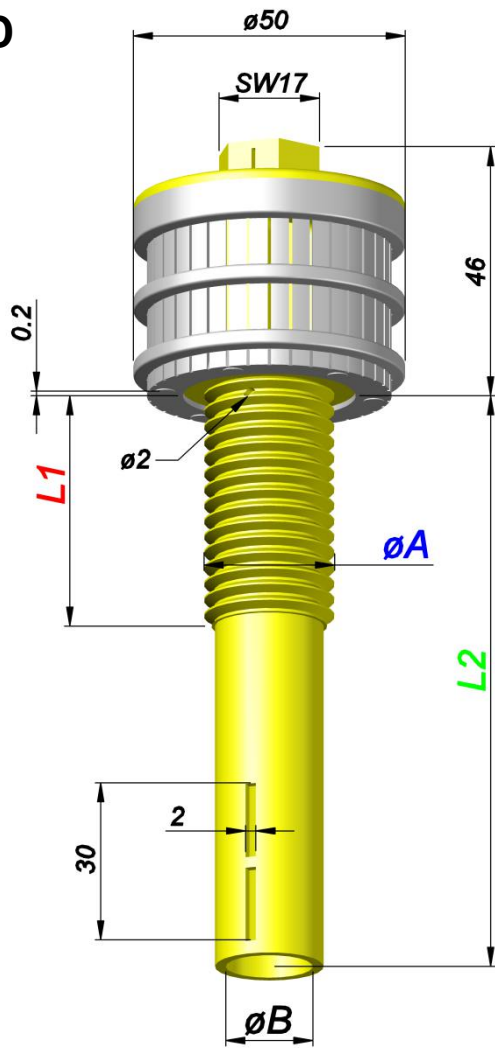

Bestellung Ordering Commande Encargo	Typ Type Type Tipa	Schlitze Slots Fentes Ranuras	Gewinde Thread Filetage Rosca	ϕA	Gewindelänge Thread length Longueur de filetage Largura de la rosca	Schaft Shaft Longueur de tige Tija	ϕB
	D	24 x 0,2 = 0,91 cm ²	1 1/4" WW	32	20, 30, 45, +5+5...	80, 110, 140, 200, 250, 300, 350, ...	21 = 3,4 cm ²
		36 x 0,2 = 1,37 cm ²	M30 x 3,5	30	30		
		36 x 0,3 = 2,05 cm ²	G 3/4"	26,5	20, 30, 45, +5+5...	80, 110, 140, 200, 250, 300, 350, ...	16 = 2,0 cm ²
		36 x 0,5 = 3,42 cm ²	1" WW	25,4	20, 45, +5+5...		
		36 x 0,8 = 5,46 cm ²	M24	24	25, 45, +5+5...		
		24 x 1,0 = 4,56 cm ²	M22 x 1,5	22	45, +5+5...		
		24 x 1,5 = 6,84 cm ²	G 1/2"	21	20	80, 110, 140, 200, ...	13 = 1,3 cm ²
		20 x 2,0 = 7,00 cm ²	M20	20	45, +5+5...		
		8 x 2,5 = 3,5 cm ²	G 3/8"	16,7	20		
		8 x 5,0 = 7,00 cm ²					

Filterdüsen

Filter-Nozzles

Crépines à filtre

Toberas filtrantes

Typ DSP

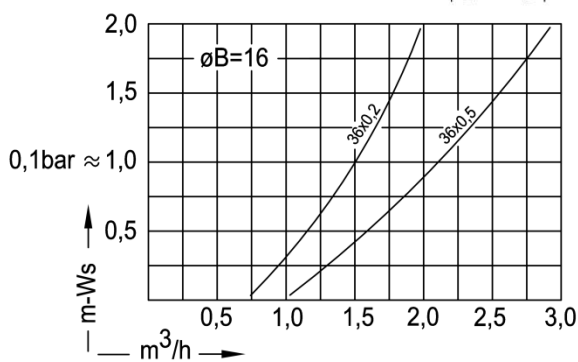
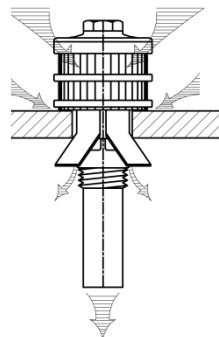
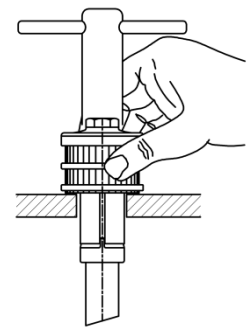
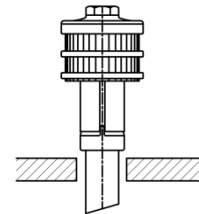
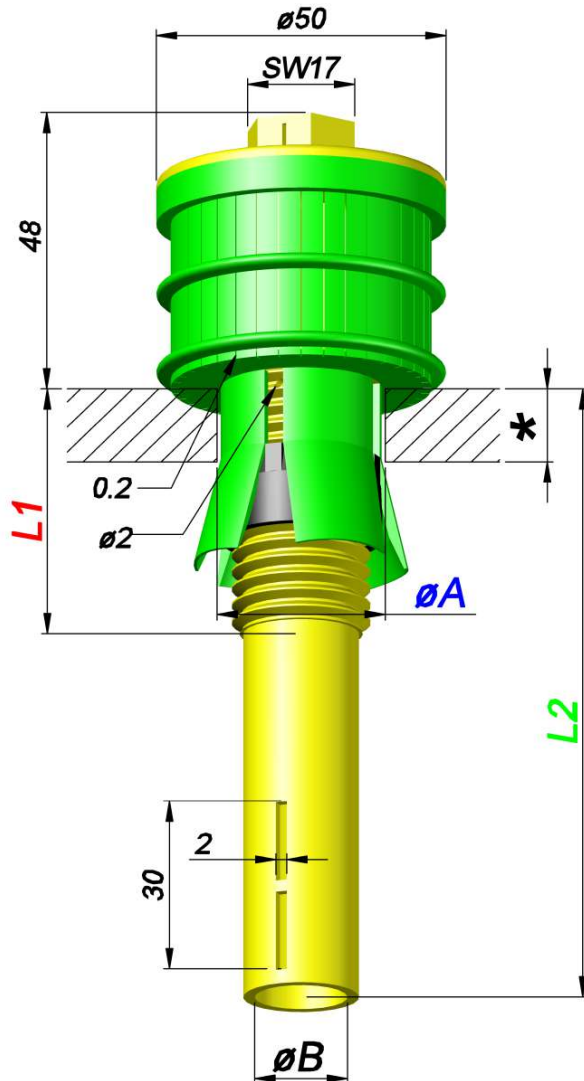

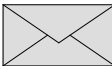
Bestellung Ordering Commande Encargo	Typ Type Type Tipa	Schlitze Slots Fentes Ranuras	*	L1	Schaft Shaft Longueur de tige Tija	L2	øA	øB
	DSP	36 x 0,2 = 1,37 cm ²	8 - 28	50	80, 110, 140, 200, 250		28-29,5; 29,5-31,5; 31,5-33;	16 = 2,0 cm ²
		36 x 0,3 = 2,05 cm ²	25 - 45	73	110, 140, 200, 250		33-34,5; 34,5-36;	
		36 x 0,5 = 3,42 cm ²						
		36 x 1,0 = 6,84 cm ²						
			36 x 0,2 = 1,37 cm ²	8-28	50	100, 110, 140, max. 200	25-27,5	13 = 1,3 cm ²
			36 x 0,3 = 2,05 cm ²	8-28	50	100, 110, 140, max. 200	26 - 28	
			36 x 0,5 = 3,42 cm ²	25- 45	73	100, 110, 140, max. 200	25-27,5	
				25- 45	73	100, 110, 140, max. 200	26 - 28	

Typ C1

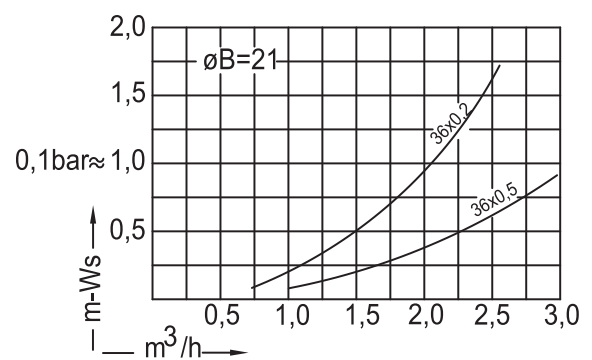
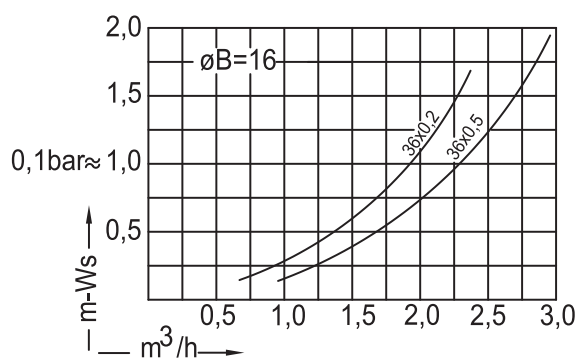
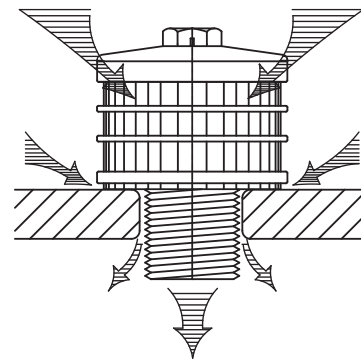
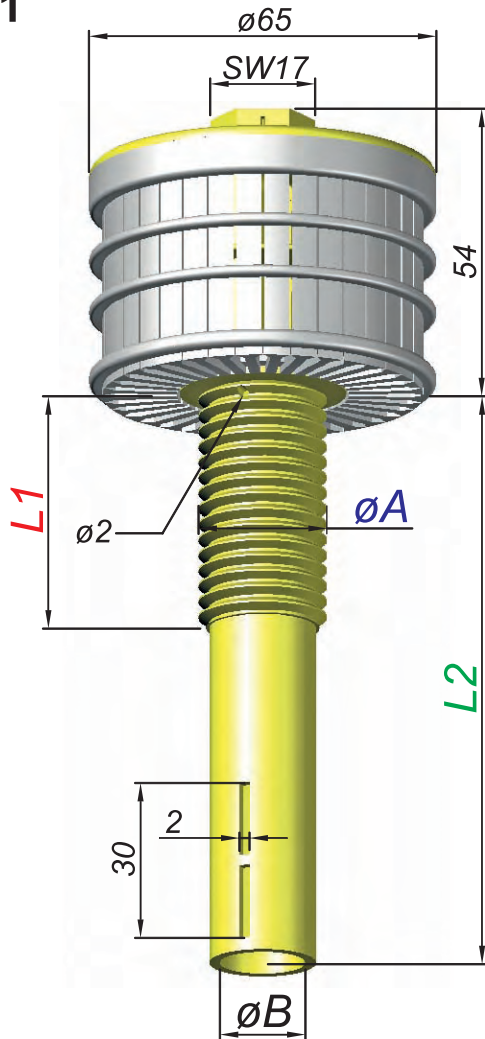

Bestellung Ordering Commande Encargo	Typ Type Type Tipa	Schlitze Slots Fentes Ranuras	Gewinde Thread Filetage Rosca	$\varnothing A$	Gewindelänge Thread length Longueur de filetage Largura de la rosca	Schaft Shaft Longueur de tige Tija	$\varnothing B$
					L1	L2	
	C1	36 x 0,2 = 1,95 cm ²	1¼"WW	32	25, 30, 45	80, 110, 140, 200, 250, 300, 350, ...	21 = 3,4 cm ²
		36 x 0,3 = 2,90 cm ²	M30	30 x 3.5	30		
		36 x 0,5 = 4,90 cm ²	G 3/4"	26,5	20, 45, +5+5...		
		36 x 0,7 = 6,80 cm ²	1"WW	25,4	20, 45, +5+5...	80, 110, 140, 200, 250, 300, 350, ...	16 = 2,0 cm ²
		36 x 1,0 = 9,80 cm ²	M24	24	20, 45, +5+5...		

Filterdüsen

Filter-Nozzles

Crépines à filtre

Toberas filtrantes

Typ C2

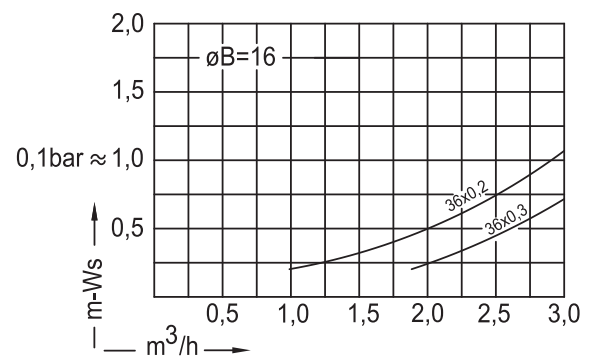
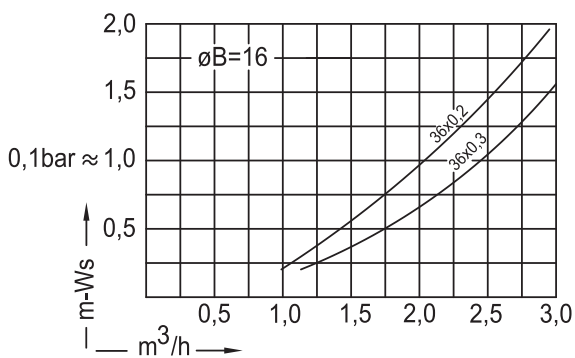
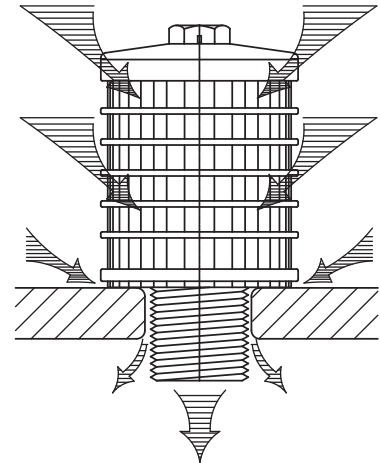
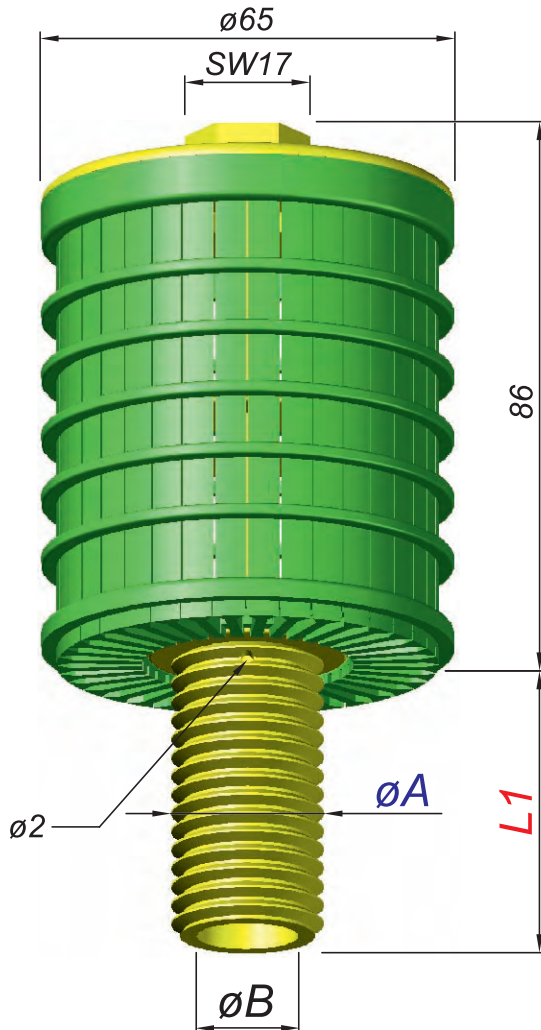

Bestellung Ordering Commande Encargo	Typ Type Type Tipa	Schlitze Slots Fentes Ranuras	Gewinde Thread Filetage Rosca	øA	Gewindelänge Thread length Longueur de filetage Largura de la rosca	L1	øB
	C2	36 x 0,2 = 3,70 cm ² 36 x 0,3 = 5,50 cm ² 36 x 0,5 = 9,61 cm ²	1¼"WW	32	25, 30, 45		21 = 3,4 cm ²
			M30 x 3.5	30	30		
			G 3/4"	26,5	20, 45, +5+5...		
			1"WW	25,4	45		
			M24	24	20, 45, +5+5...		
							16 = 2,0 cm ²

Filterdüsen

Filter-Nozzles

Crépines à filtre

Toberas filtrantes

Typ K2

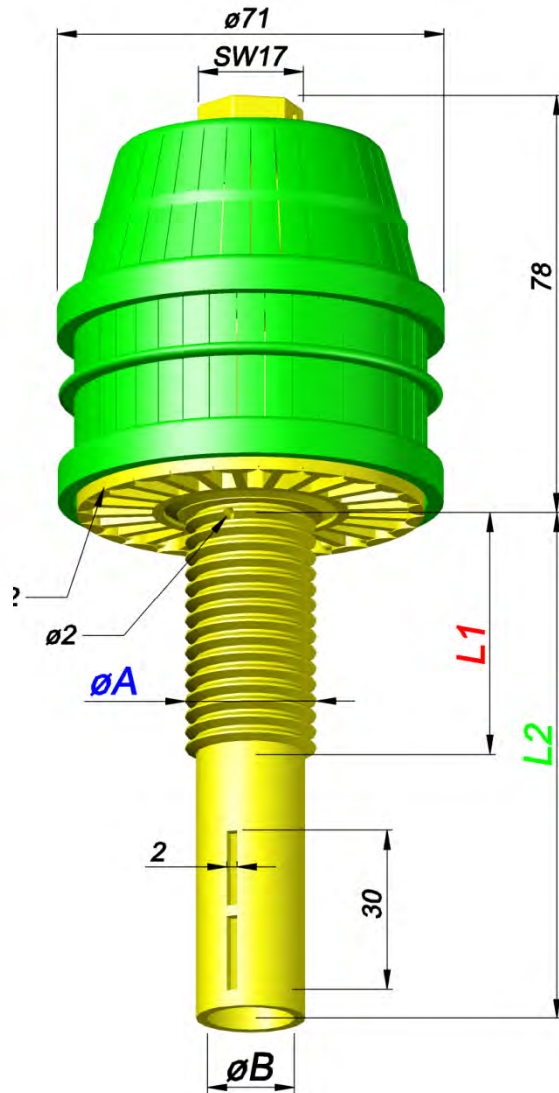

Typ K2

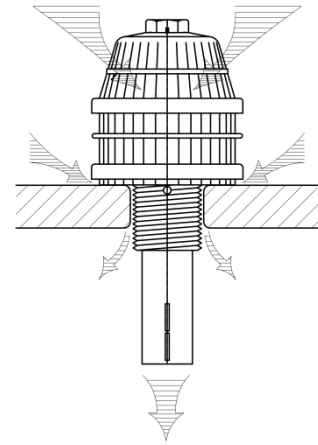

Typ KR2

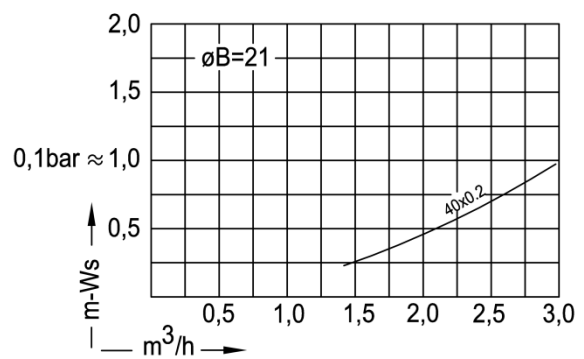
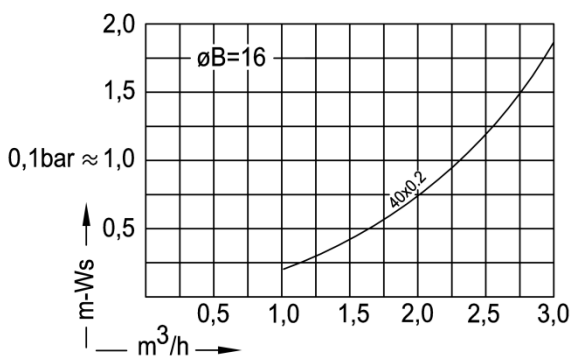
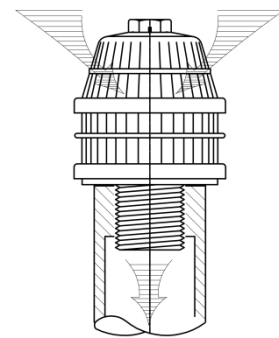

Bestellung Ordering Commande Encargo	Typ Type Type Tipa	Schlitze Slots Fentes Ranuras	Gewinde Thread Filetage Rosca	øA	Gewindelänge Thread length Longueur de filetage Largura de la rosca	Schaft Shaft Longueur de tige Tija	øB
✉	K2	40 x 0,2 = 3,63 cm² 40 x 0,35 = 6,35 cm²	1 1/4"WW	32	25, 45	80, 110, 140, ...	21 = 3,4 cm²
			M30 x 3.5	30	30		
			G 3/4"	26,5	25, 45	80, 110, 140, ...	16 = 2,0 cm²
			M24	24	25, 45		
	KR2						

Filterdüsen

Filter-Nozzles

Crépines à filtre

Toberas filtrantes

Typ P

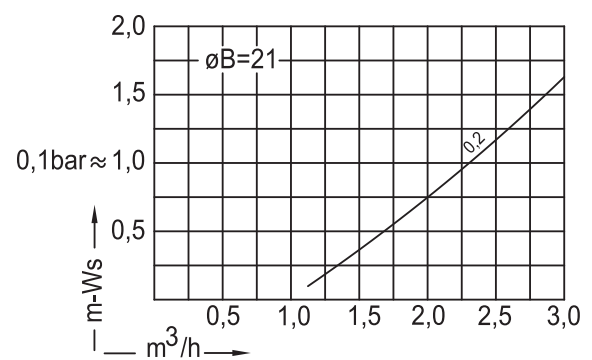
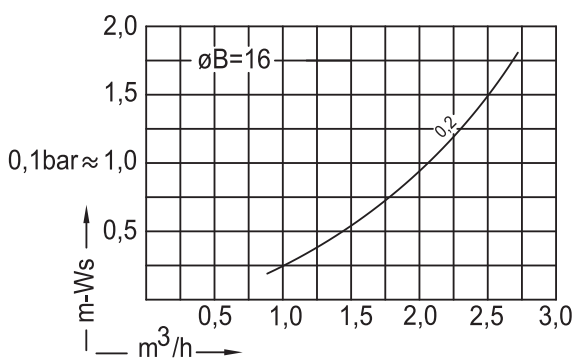
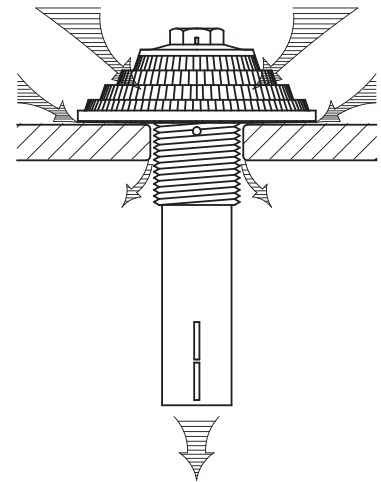
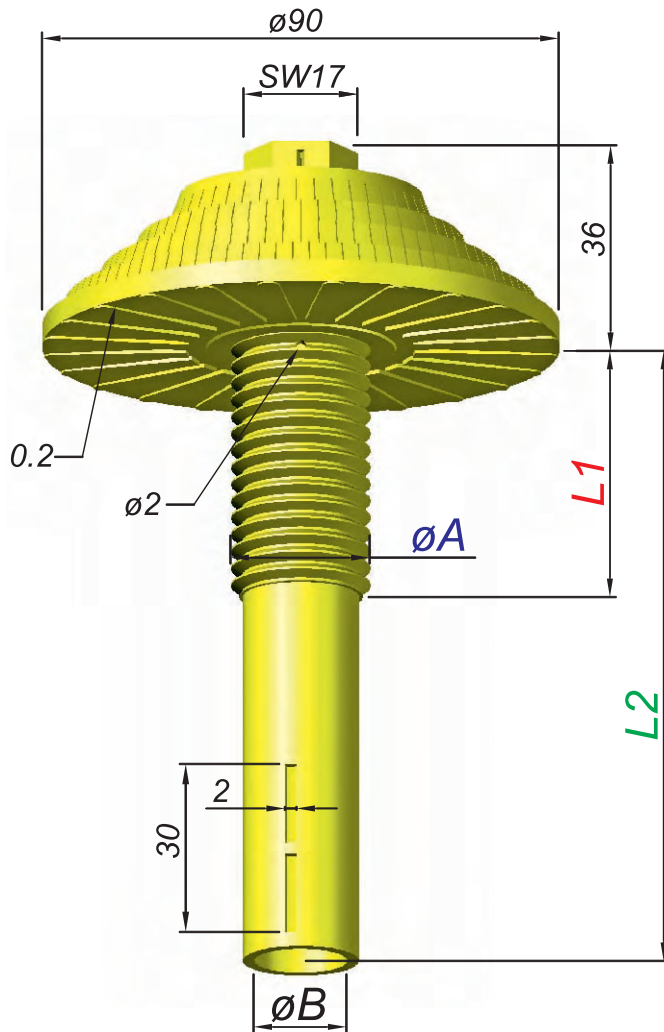

Bestellung Ordering Commande Encargo	Typ Type Type Tipa	Schlitze Slots Fentes Ranuras	Gewinde Thread Filetage Rosca	$\varnothing A$	Gewindelänge Thread length Longueur de filetage Largura de la rosca	Schaft Shaft Longueur de tige Tija	$\varnothing B$
	P	0,2 = 3,0 cm ²	1½"WW	32	25, 45, +5 +5 ...	80, 110, 140	21 = 3,4 cm ²
			G 3/4"	26,5	20, 45, +5 +5 ...	80, 110, 140	16 = 2,0 cm ²
			1"WW	25,4	20, 45		
			M24	24	20, 45, +5 +5 ...		

Filterdüsen

Filter-Nozzles

Crépines à filtre

Toberas filtrantes

Typ L
/ LR

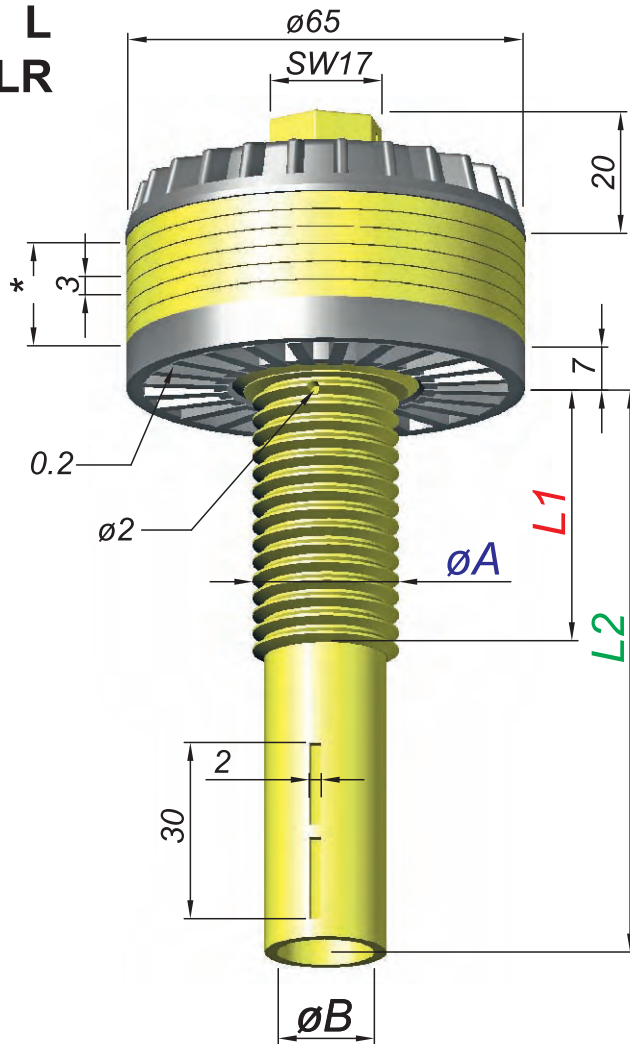

Typ L6

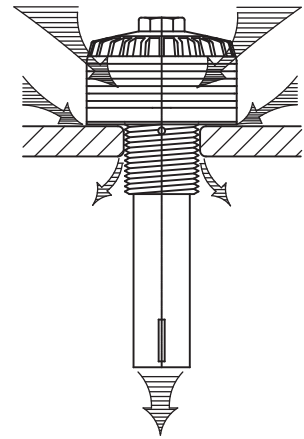

Typ LR6

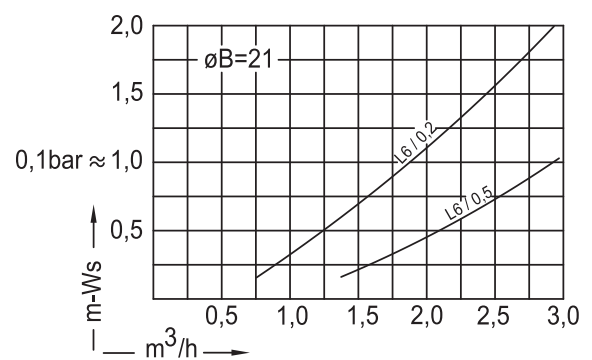
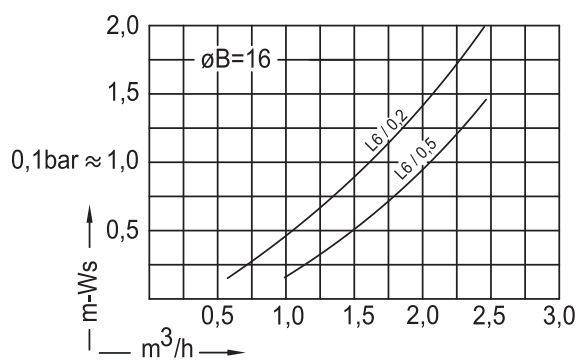
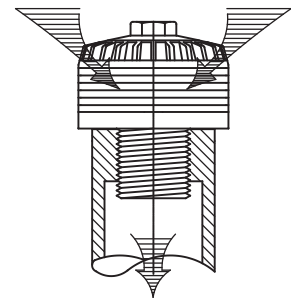

Bestellung Ordering Commande Encargo	Typ Type Type Tipa	*	Schlitze Slots Fentes Ranuras	pro Ring per Ring	Gewinde Thread Filetage Rosca	ϕA	Gewindelänge Thread length Longueur de filetage Largura de la rosca	Schaft Shaft Longueur de tige Tija	ϕB
							L1	L2	
✉	L LR	2	0,1 = 0,2 cm ²		1¼"WW	32	20, 30, 45, +5+5...	80, 110, 140, ...	21 = 3,4 cm ²
		5	0,15 = 0,3 cm ²		M30	30	30		
		6	0,2 = 0,4 cm ²		G 3/4"	26,5	20, 30, 45, +5+5...	80, 110, 140, ...	16 = 2,0 cm ²
		10	0,3 = 0,6 cm ²		1"WW	25,4	20, 45, +5+5...		
		12	0,5 = 1,0 cm ²		M24	24	25, 45, +5+5...		
		15			M22x1,5	22	45, +5+5...		
					M20	20	45, +5+5...	80, 110, 140, ...	13 = 1,3 cm ²

Typ S1

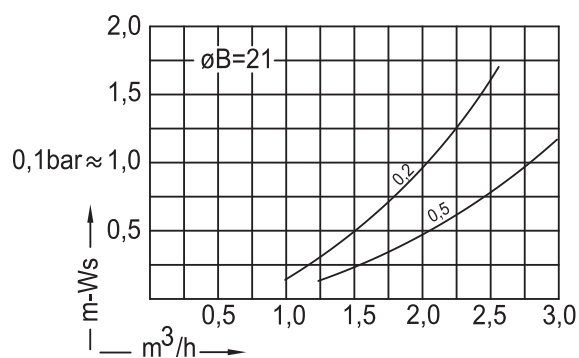
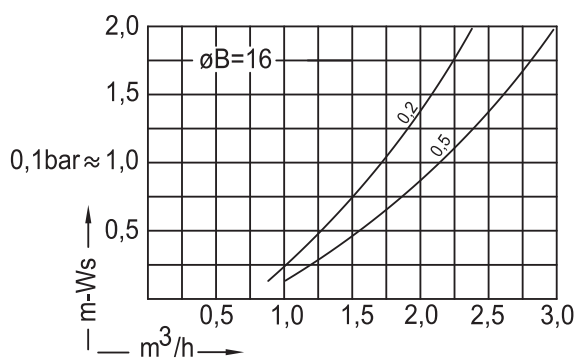
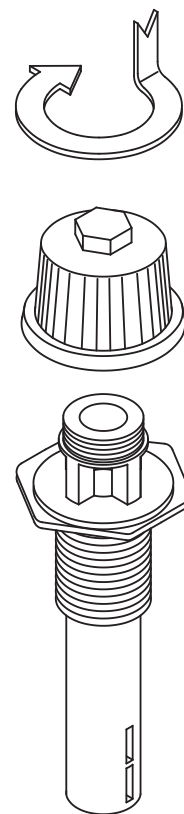
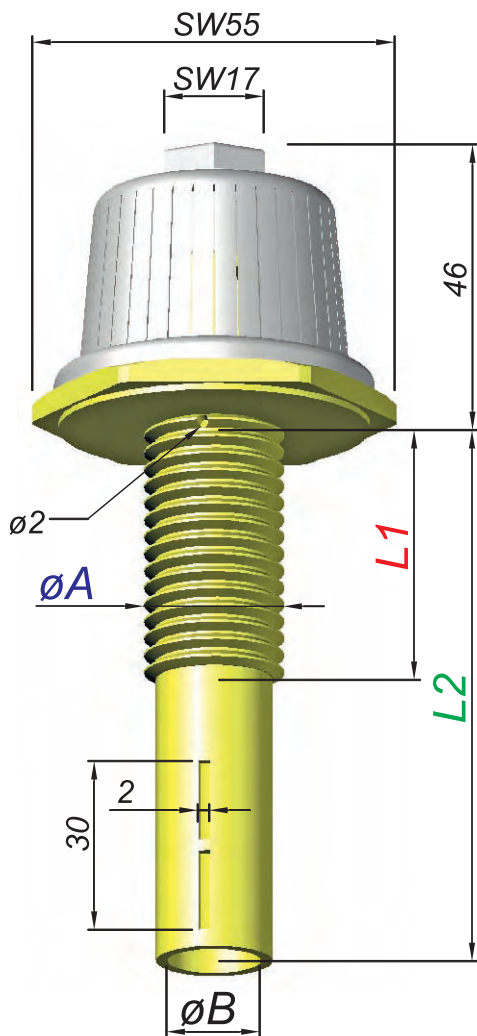

Bestellung Ordering Commande Encargo	Typ Type Type Tipa	Schlitz Slots Fentes Ranuras	Gewinde Thread Filetage Rosca	øA	Gewindelänge Thread length Longueur de filetage Largura de la rosca	Schaft Shaft Longueur de tige Tija	øB
	S1	36 x 0,2 = 1,72 cm ² 36 x 0,35 = 2,65 cm ² 30 x 0,5 = 3,78 cm ² 18 x 1,0 = 4,64 cm ² 18 x 2,0 = 9,29 cm ²	G 1"	33,25	20	80, 110, 140, 200, 250, 300, 350, ...	21 = 3,4 cm ²
			1¼"WW	32	25, 30, 45		
			M30	30	30		
			G 3/4"	26,5	20, 45, 50, +5 +5...	80, 110, 140, 200, 250, 300, 350, ...	16 = 2,0 cm ²
			1"WW	25,4	45		
			M24	24	20, 45, 50, +5 +5...		

Filterdüsen

Filter-Nozzles

Crépines à filtre

Toberas filtrantes

Typ S3

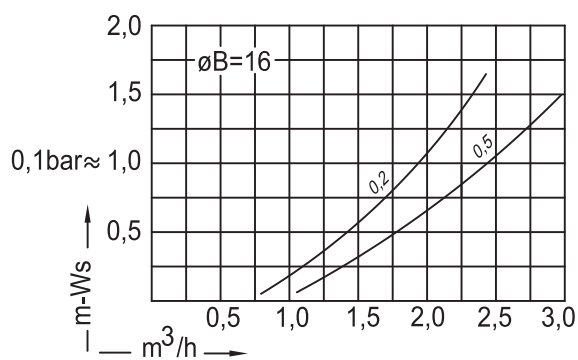
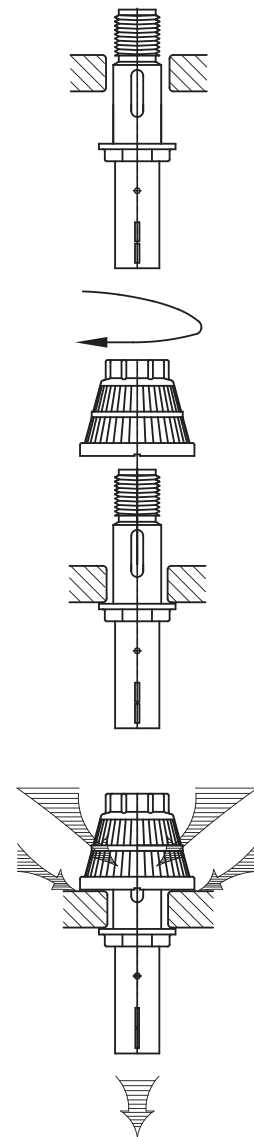
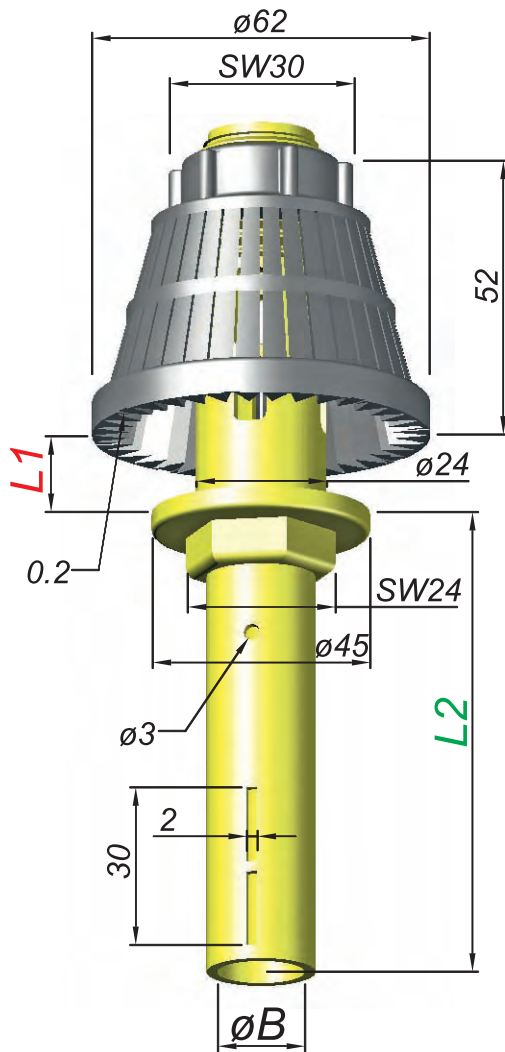

Bestellung Ordering Commande Encargo	Typ Type Type Tipa	Schlitze Slots Fentes Ranuras	Bodenstärke plate thickness Epaisseur du plancher Espesor placa	Schaft Shaft Longueur de tige Tija	øB
	S3	40 x 0,2 = 3,04 cm ² 40 x 0,5 = 5,84 cm ² 40 x 0,7 = 8,18 cm ²	6 - 12	80, 110, 140, ...	16 = 2,0 cm ²
			12 - 20		
			20 - 30		
			30 - 40		

Filterdüsen

Filter-Nozzles

Crépines à filtre

Toberas filtrantes

Typ G

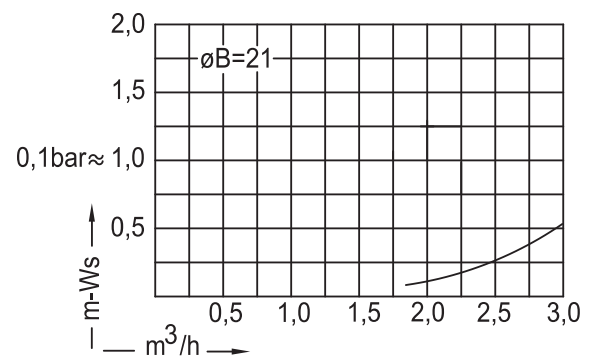
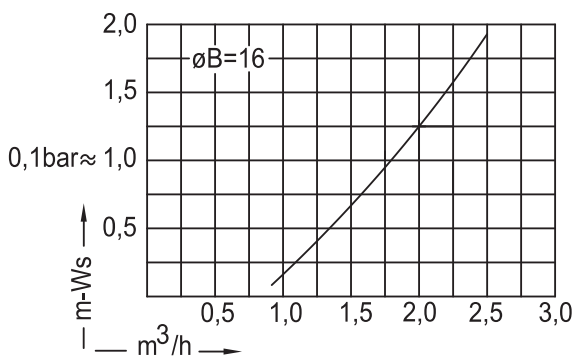
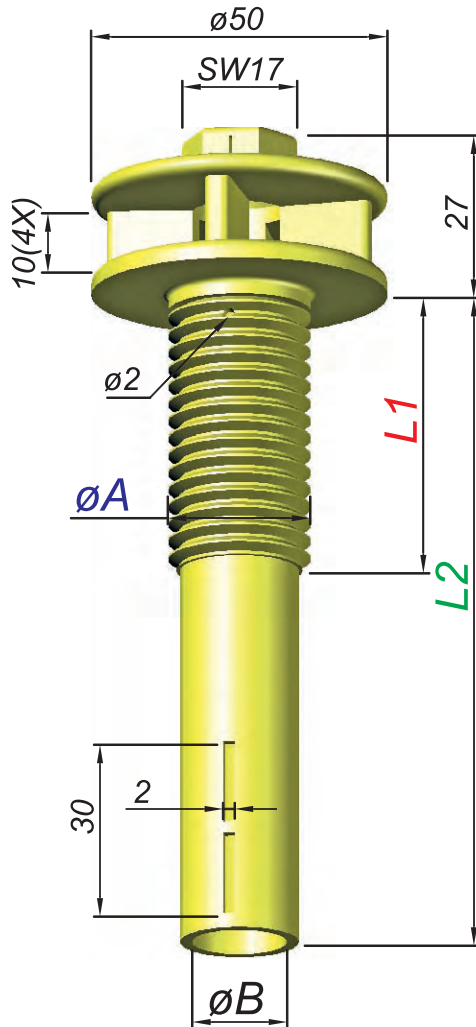

Bestellung Ordering Commande Encargo	Typ Type Type Tipa	Schlitz Slots Fentes Ranuras	Gewinde Thread Filetage Rosca	øA	Gewindelänge Thread length Longueur de filetage Largura de la rosca	Schaft Shaft Longueur de tige Tija	øB
	G	5 = 2,0 cm ²	G 1"	33,25	20	80, 110, 140, 200, 250, 300, 350, ...	21 = 3,4 cm ²
			1½" WW	32	20, 30, 45, +5+5...		
			M30 x 3.5	30	30		
			G 3/4"	26,5	20, 30, 45, +5+5...	80, 110, 140, 200, 250, 300, 350, ...	16 = 2,0 cm ²
			1" WW	25,4	20, 45, +5+5...		
			M24	24	25, 45, +5+5...		
			M22 x 1,5	22	45, +5+5...		

Filterdüsen

Filter-Nozzles

Crépines à filtre

Toberas filtrantes

Typ V10

V4A
(316L)

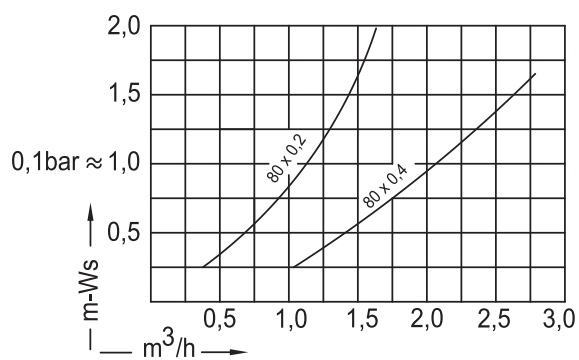
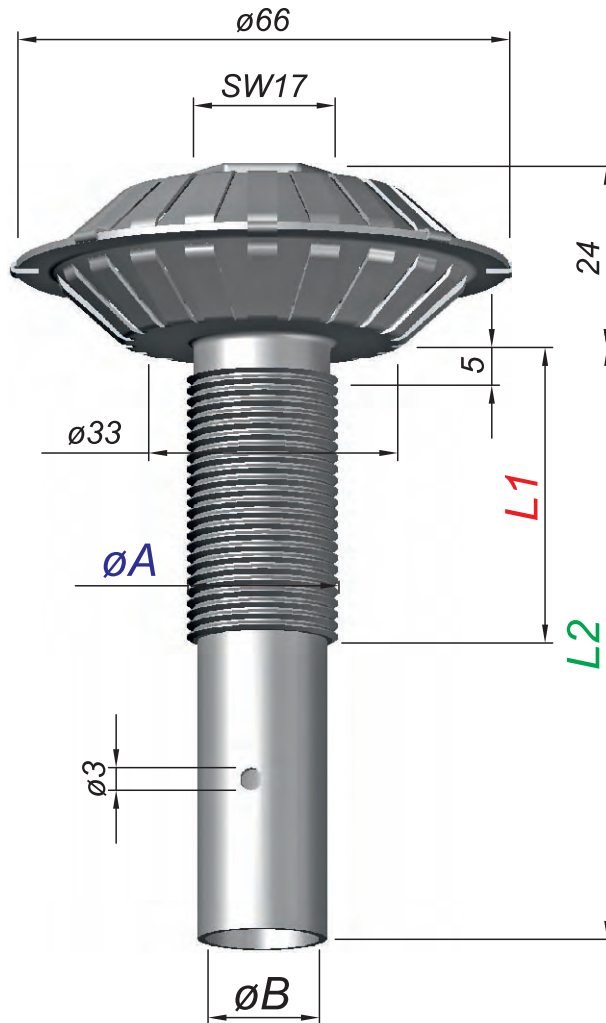

Typ MUVA

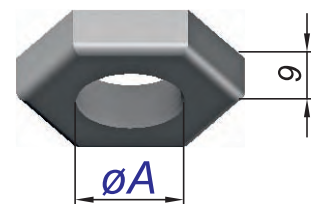

Bestellung Ordering Commande Encargo	Typ Type Type Tipa	Schlitze Slots Fentes Ranuras	Gewinde Thread Filetage Rosca	øA	Gewindelänge Thread length Longueur de filetage Largura de la rosca	Schaft Shaft Longueur de tige Tija	øB
	V10	80 x 0,2 = 1,68 cm ² 80 x 0,4 = 3,52 cm ²	M20x1,5	20	35 +5 +5 ...	80, 100, ...	16 = 2,0 cm ²
	MUVA		M20x1,5				

Filterdüsen

Filter-Nozzles

Crépines à filtre

Toberas filtrantes

Typ V20

V4A
(316L)

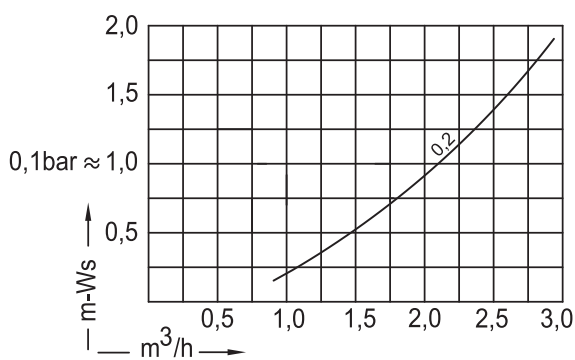
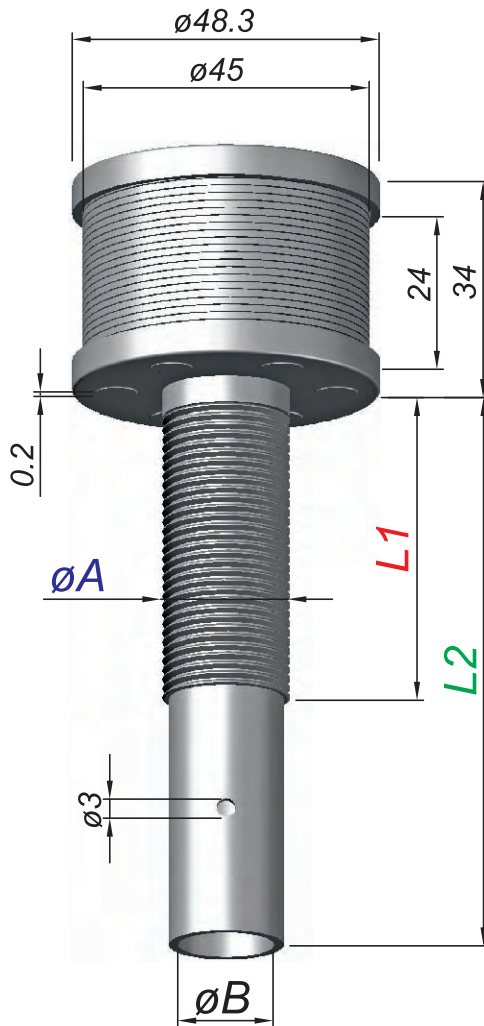

Typ MUVA

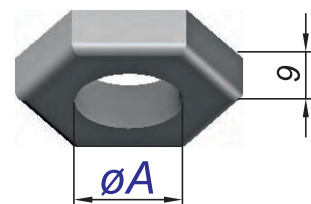

Bestellung Ordering Commande Encargo	Typ Type Type Tipa	Schlitz Slots Fentes Ranuras	Gewinde Thread Filetage Rosca	øA	Gewindelänge Thread length Longueur de filetage Largura de la rosca	Schaft Shaft Longueur de tige Tija	øB
	V20	0,2 = 5,65 cm ²	M20x1,5	20	40, +5 +5...	80, 100, ...	16 = 2.0 cm ²
	MUVA		M20x1,5				

Filterdüsenatz

für Zwischenböden

Filter-Nozzles-Set

For intermediate bottoms

Crépines à filtre

Assortiment pour planches intermédiaies

Conjuto de

Toberas para placas intermedias



Filterdüsenatz
für Zwischenböden

Filter-Nozzles-Set
For intermediate bottoms

Crépines à filtre
Assortiment pour planches
intermédiaies

Conjuto de
Toberas para
placas intermedias

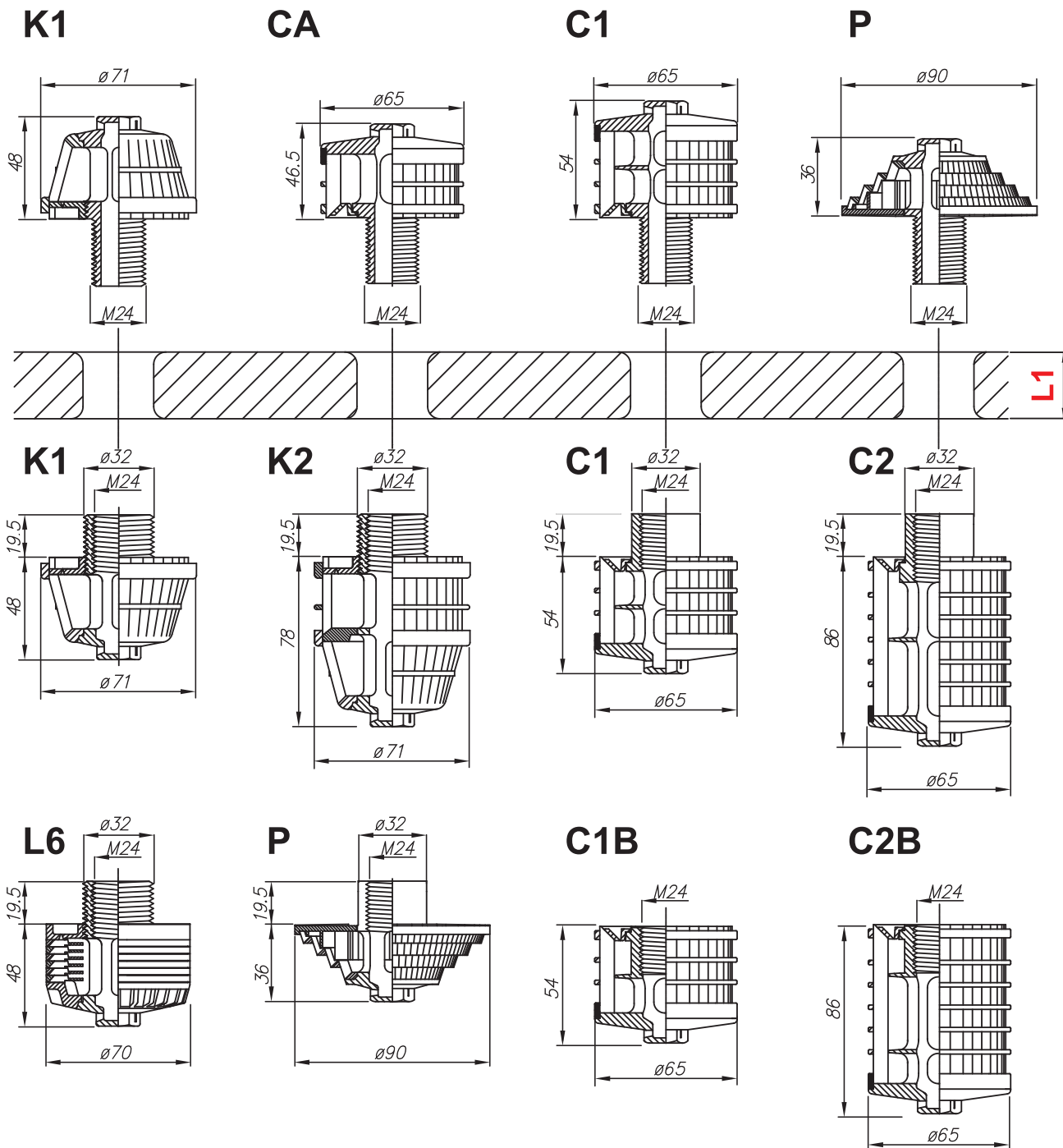

Bestellung Ordering Commande Encargo	Typ obere Düse Type upper nozzle Type crépines supérieures Tipo toberas Superior	Schlitz Slots Fentes Ranuras	Typ untere Düse Type lower nozzle Type crépines inférieures Tipo tobera Inferior	Schlitz Slots Fentes Ranuras	Bodenstärke Plate thickness Epaisseur du plancher Espesor placa
	K1	0,2 0,35 0,5	K1	0,2 0,35 0,5 - 2,0	 L1 = mm
	C1	0,2 0,3 0,5	K2	0,2 0,35	
	P	0,2	C1	0,2 0,3 0,5 - 2,0	
	CA	0,4	C1B	0,2 0,3 0,5 - 2,0	
			C2	0,2 0,3	
			C2B	0,2 0,3	
			L	0,2 0,3 0,5	
			P	0,2	

Gegenstromventil

Zur besseren Verteilung der Regeneriermittel

Counter Flow Valve

For the uniform distribution of the regenerants

Soupape à contre

Pour une meilleure répartition des solutions de régénération

Valvula de contra

Para la distribución uniforme de los reactivos de regeneracion

Typ GVU

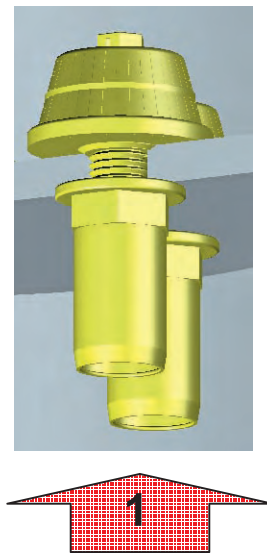
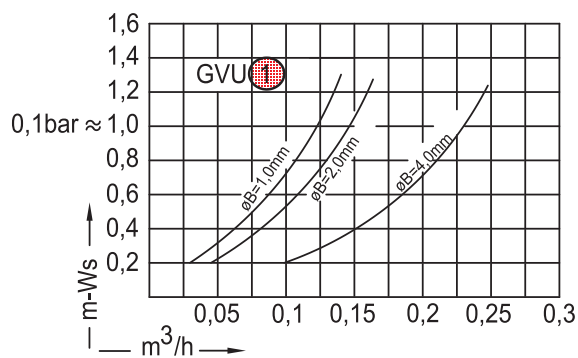
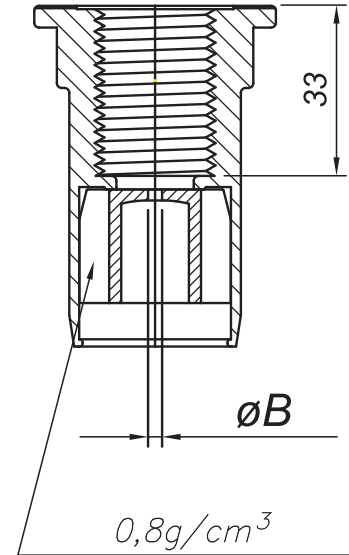
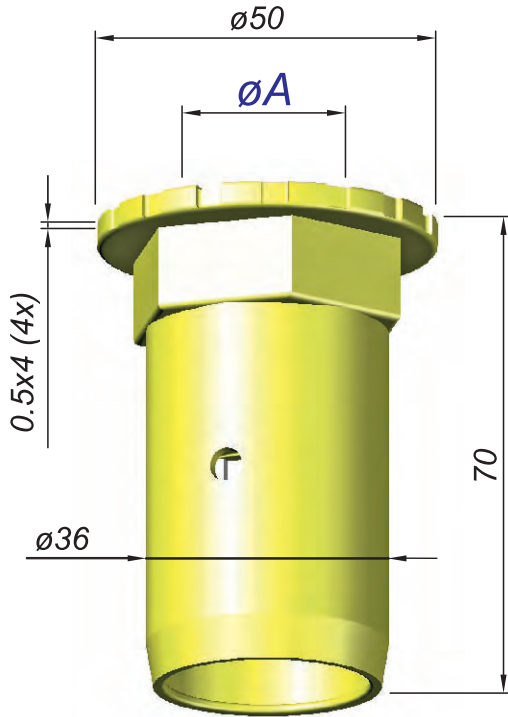

Bestellung Ordering Commande Encargo	Typ Type Type Tipa	Gewinde Thread Filetage Rosca	ϕA	ϕB
	GVU	1¼" WW	32	$\phi 1,0 - \phi 2,0 - \phi 3,0 - \phi 4,0 - \phi 5,0 - \phi 6,0 - \phi 7,0$ mm
		G 3/4"	26,5	
		M24	24	
		M20	20	

Gegenstromventil

Zur besseren Verteilung der Regeneriermittel

Counter Flow Valve

For the uniform distribution of the regenerants

Soupape à contre

Pour une meilleure répartition des solutions de régénération

Valvula de contra

Para la distribución uniforme de los reactivos de regeneracion

Typ GVO

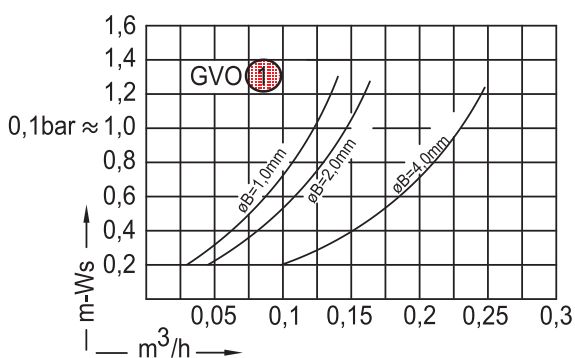
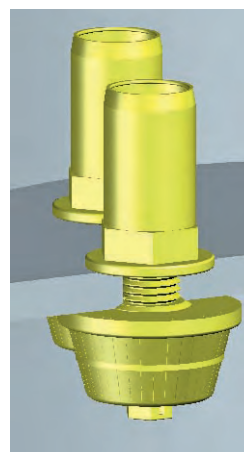
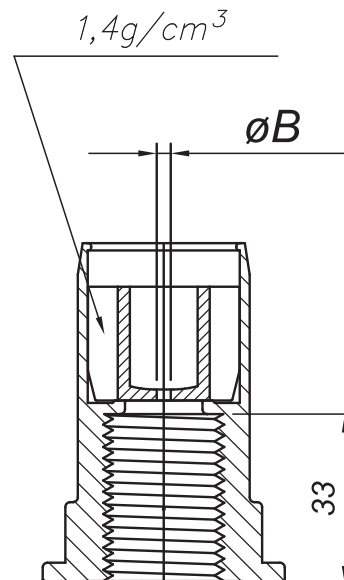
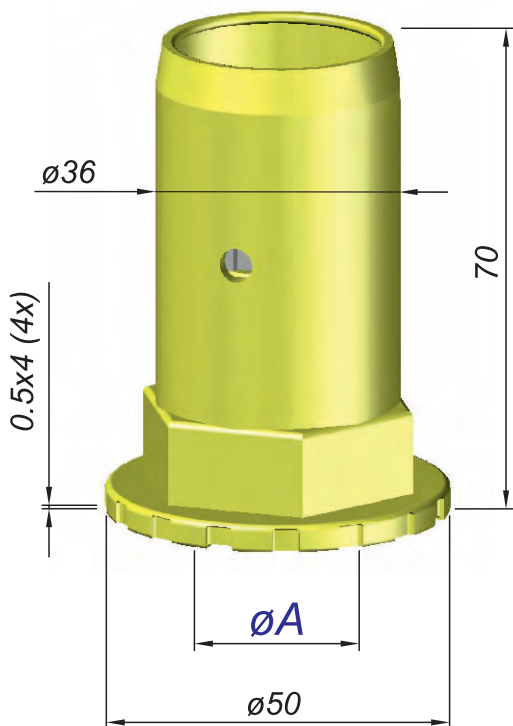

Bestellung Ordering Commande Encargo	Type Type Type Tipa	Gewinde Thread Filetage Rosca	øA	øB
	GVO	1¼" WW	32	ø1,0 - ø2,0 - ø3,0 - ø4,0 - ø5,0 - ø6,0 - ø7,0 mm
		G 3/4"	26,5	
		M24	24	
		M20	20	

Filterdüsen

Zur besseren Verteilung der Regeneriermittel

Filter-Nozzles

For the uniform distribution of the regenerants

Crépines à filtre

Pour une meilleure répartition des solutions de régénération

Toberas filtrantes

Para la distribución uniforme de los reactivos de regeneración

Typ PKU

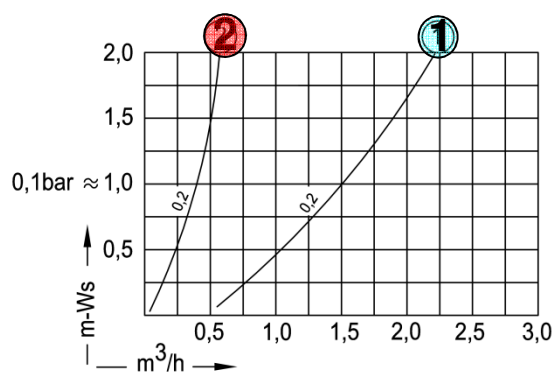
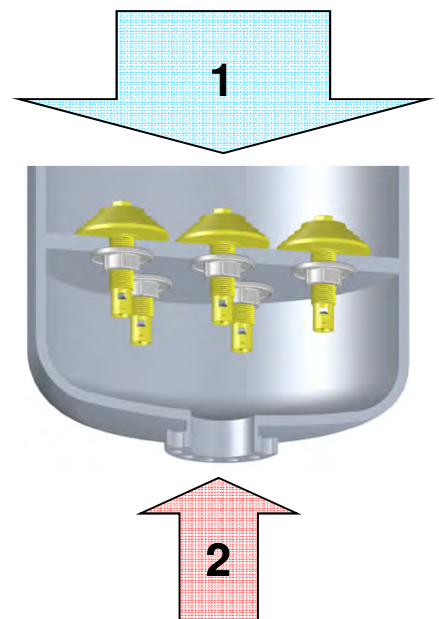
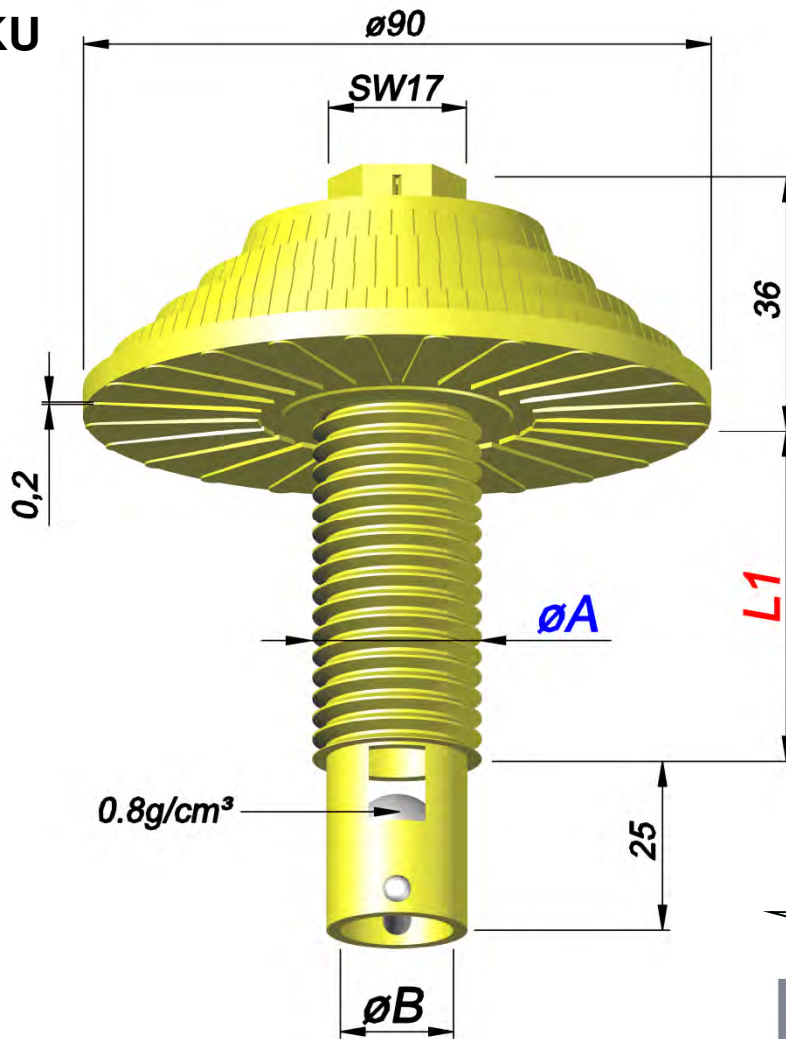

Bestellung Ordering Commande Encargo	Typ Type Type Tipa	Schlitz Slots Fentes Ranuras	Gewinde Thread Filetage Rosca	øA	L1	øB
	PKU	0,2 = 3,0 cm ² 0,3 = 4,5 cm ²	M24	24	45, 50, +5 +5...	16 = 2,0 cm ²

Filterdüsen

Zur besseren Verteilung der Regeneriermittel

Filter-Nozzles

For the uniform distribution of the regenerants

Crépines à filtre

Pour une meilleure répartition des solutions de régénération

Toberas filtrantes

Para la distribución uniforme de los reactivos de regeneración

Typ PKO

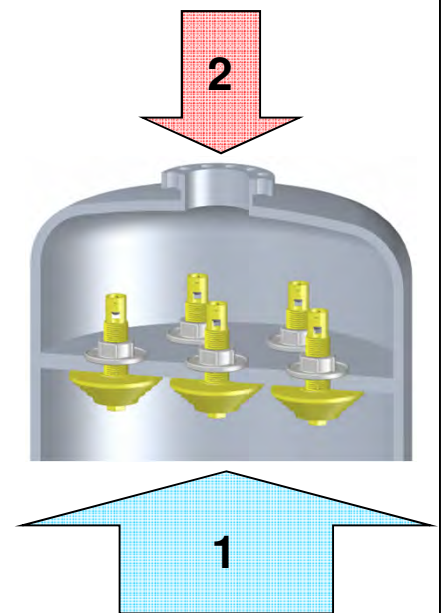
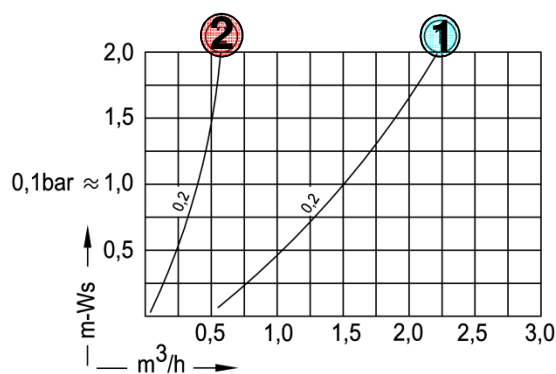
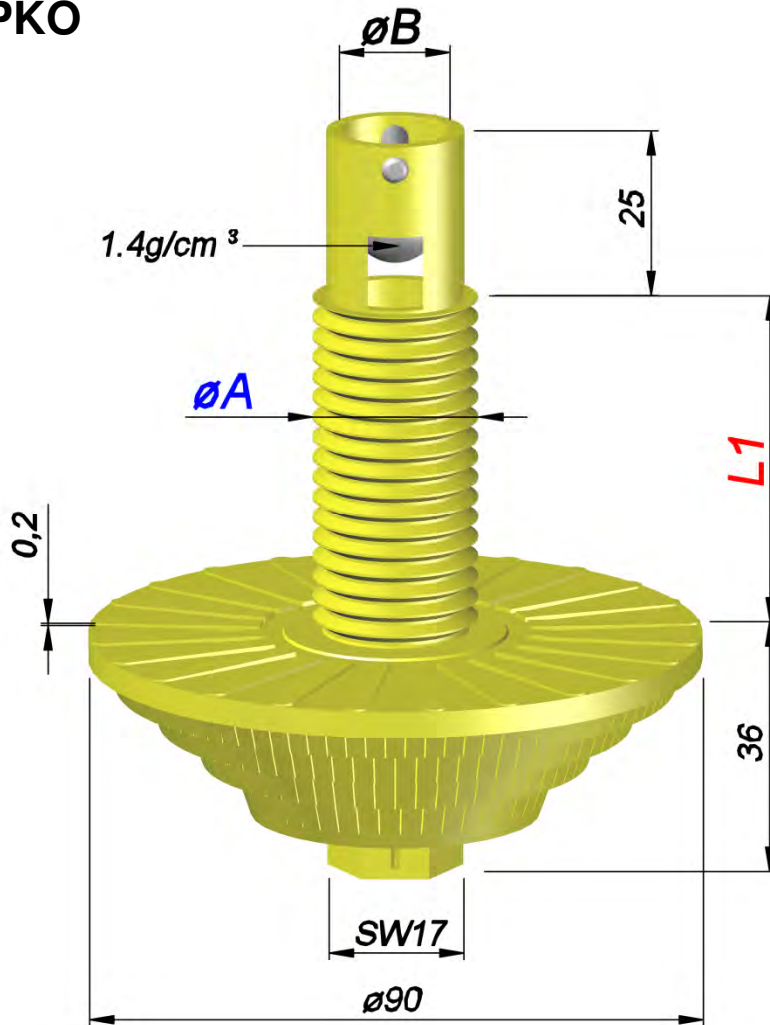

Bestellung Ordering Commande Encargo	Typ Type Type Tipa	Schlitze Slots Fentes Ranuras	Gewinde Thread Filetage Rosca	$\varnothing A$	$L1$	$\varnothing B$
	PKO	0,2 = 3,0 cm ² 0,3 = 4,5 cm ²	M24	24	45, 50, +5 +5...	16 = 2,0 cm ²

Mischbett
Filterdüsen

Mixbed
Filter-Nozzles

Crépines à filtre
Pour lit mélange

Toberas filtrantes
Para lechos mixtos

Typ M

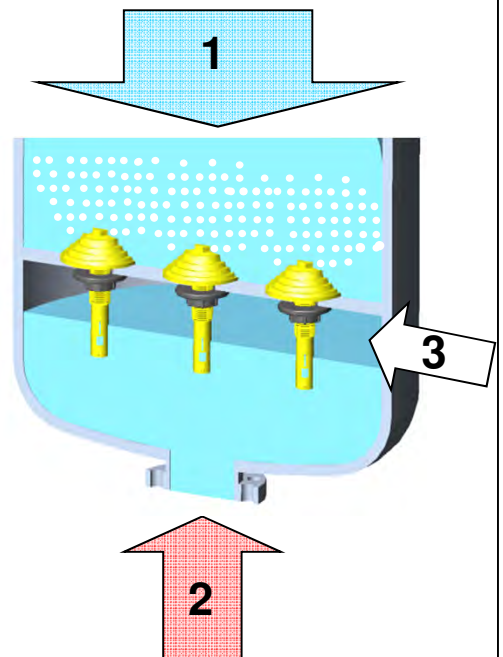
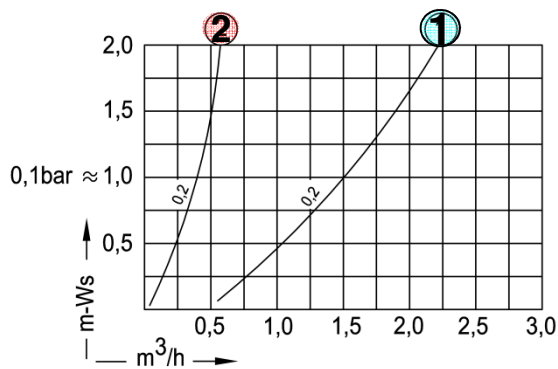
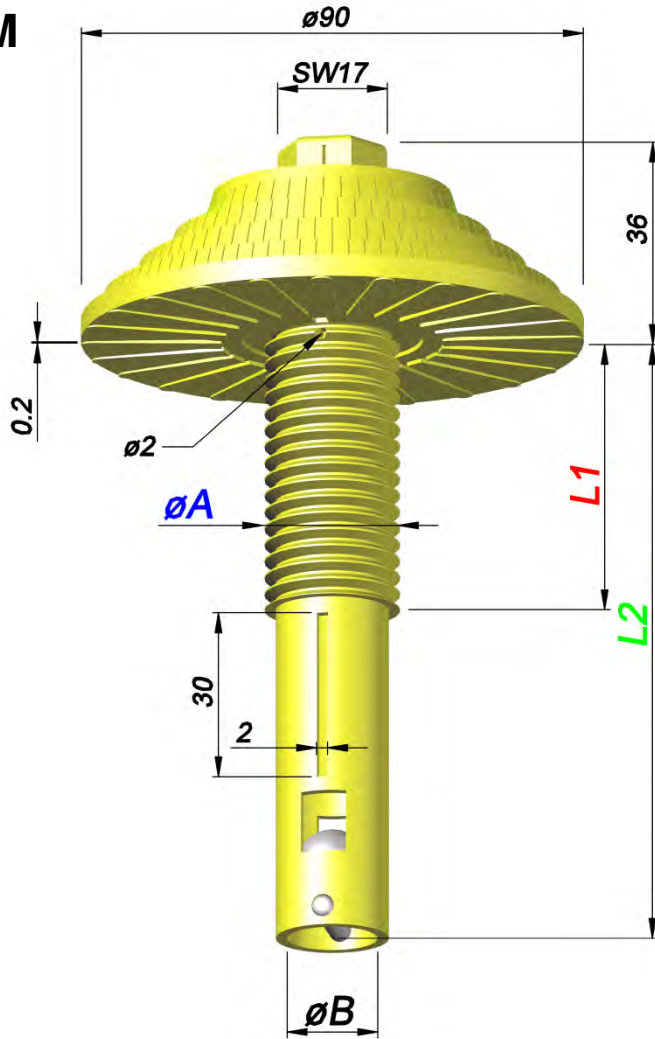

Bestellung Ordering Commande Encargo	Typ Type Type Tipa	Schlitz Slots Fentes Ranuras	Gewinde Thread Filetage Rosca	øA	Gewindelänge Thread length Longueur de filetage Largura de la rosca	Schaft Shaft Longueur de tige Tija	øB
✉	M	0,2 = 3,0 cm ²	G 3/4"	26,5	50	110	16 = 2,0 cm ²
		0,3 = 4,5 cm ²	M24	24			

Filterdüsen

Filter-Nozzles

Crépines à filtre

Toberas filtrantes

Typ MDL

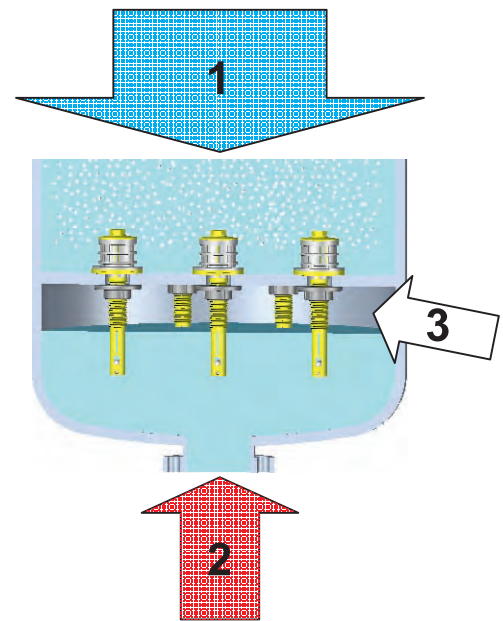
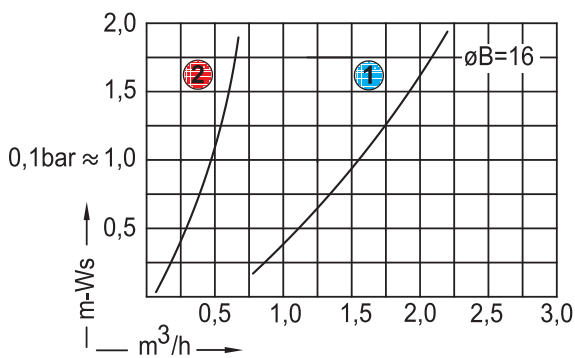
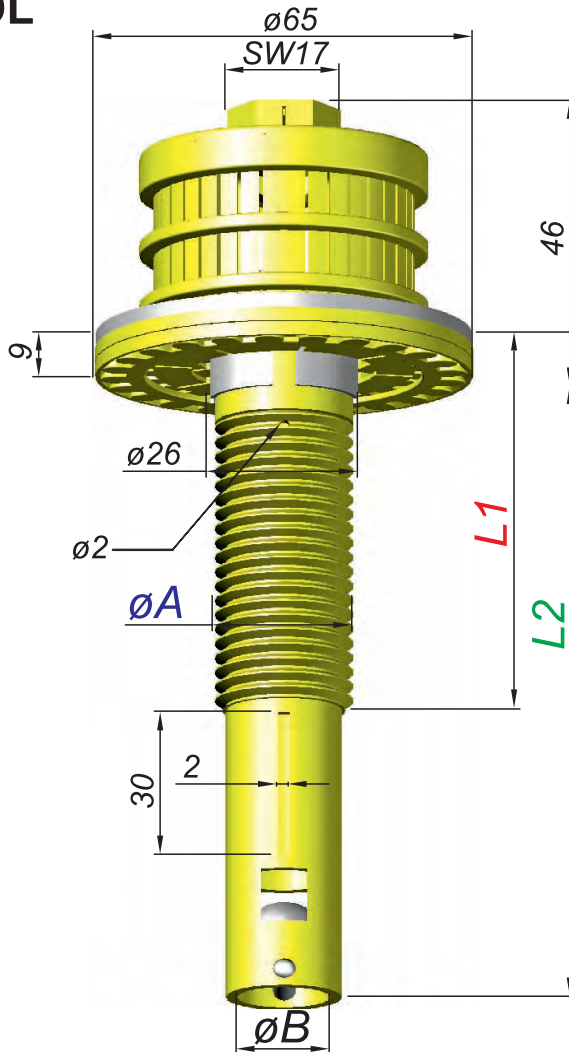

Bestellung Ordering Commande Encargo	Typ Type Type Tipa	Schlitz Slots Fentes Ranuras	Gewinde Thread Filetage Rosca	ϕA	Gewindelänge Thread length Longueur de filetage Largura de la rosca	Schaft Shaft Longueur de tige Tija	ϕB
	MDL	24 x 0,2 = 0,91 cm ² 36 x 0,2 = 1,37 cm ²	M24	24	60	120	16 = 2,0 cm ²

Filterdüsen für Drainagesystem

Filter-Nozzles for Drainage system

Système de drainage

Sistemas de drenaje

Montagebeispiel

Installation procedure

Exemple de montage

Ejemplo de montaje

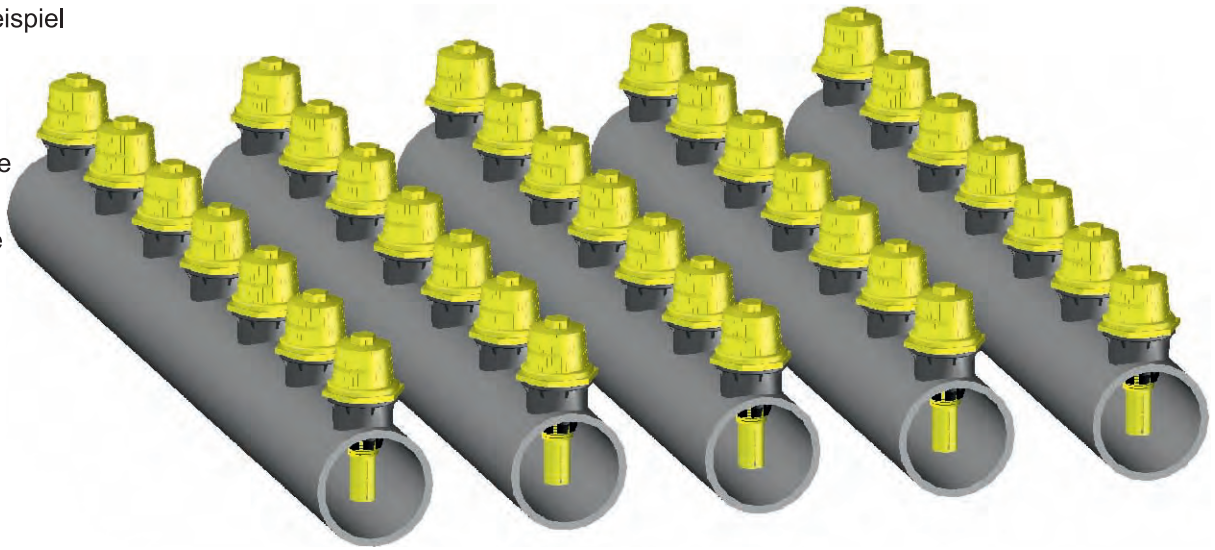

Typ ADR

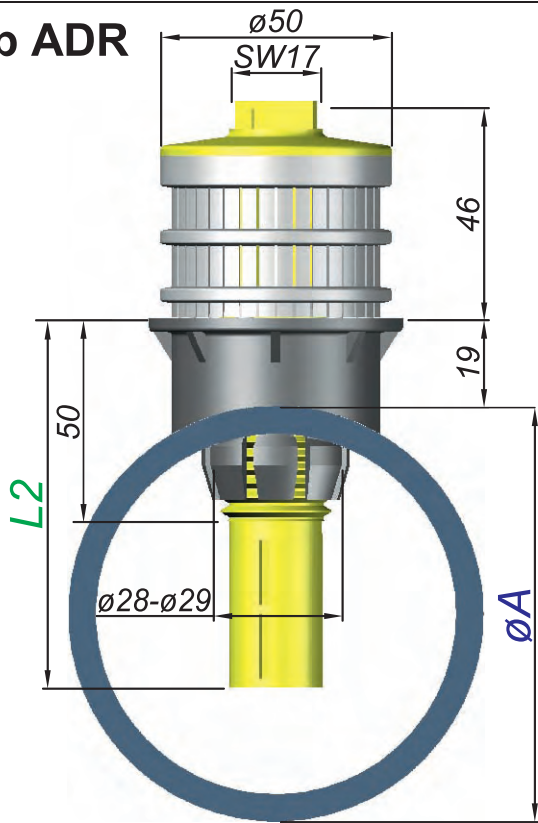

Typ ASR

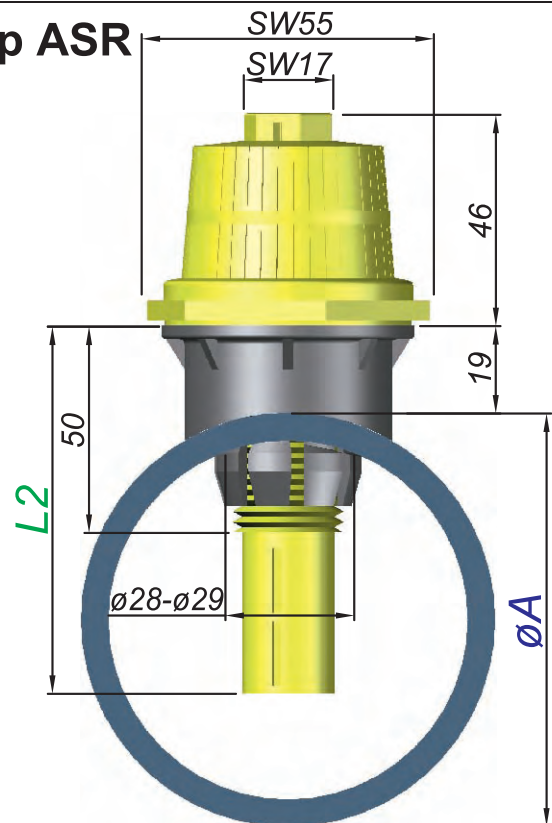

Bestellung Ordering Commande Encargo	Typ Type Type Tipa	Schlitze Slots Fentes Ranuras	$\varnothing A$	Schaft Shaft Longueur de tige Tija	$L2$	Bestellung Ordering Commande Encargo	Typ Type Type Tipa	Schlitze Slots Fentes Ranuras	$\varnothing A$	Schaft Shaft Longueur de tige Tija	$L2$
	ADR	24 x 0,2 = 0,91 cm ² 36 x 0,2 = 1,37 cm ² 36 x 0,3 = 2,05 cm ² 36 x 0,5 = 3,42 cm ² 36 x 0,8 = 5,46 cm ² 24 x 1,0 = 4,56 cm ² 24 x 1,5 = 6,84 cm ² 20 x 2,0 = 7,00 cm ² 8 x 5,0 = 7,00 cm ²	60,3 63 75 90 110	Nach Angabe according detail selon détails adecuado detalle			ASR	36 x 0,2 = 1,72 cm ² 36 x 0,35 = 2,65 cm ² 30 x 0,5 = 3,78 cm ² 18 x 1,0 = 4,64 cm ² 18 x 2,0 = 9,29 cm ²	60,3 63 75 90 110	Nach Angabe according detail selon détails adecuado detalle	

**Filterdüsen für
Drainagesystem**

**Filter-Nozzles for
Drainage system**

**Système de
drainage**

**Sistemas de
drenaje**

Montagebeispiel
Installation
procedure
Exemple
de montage
Ejemplo
de montaje

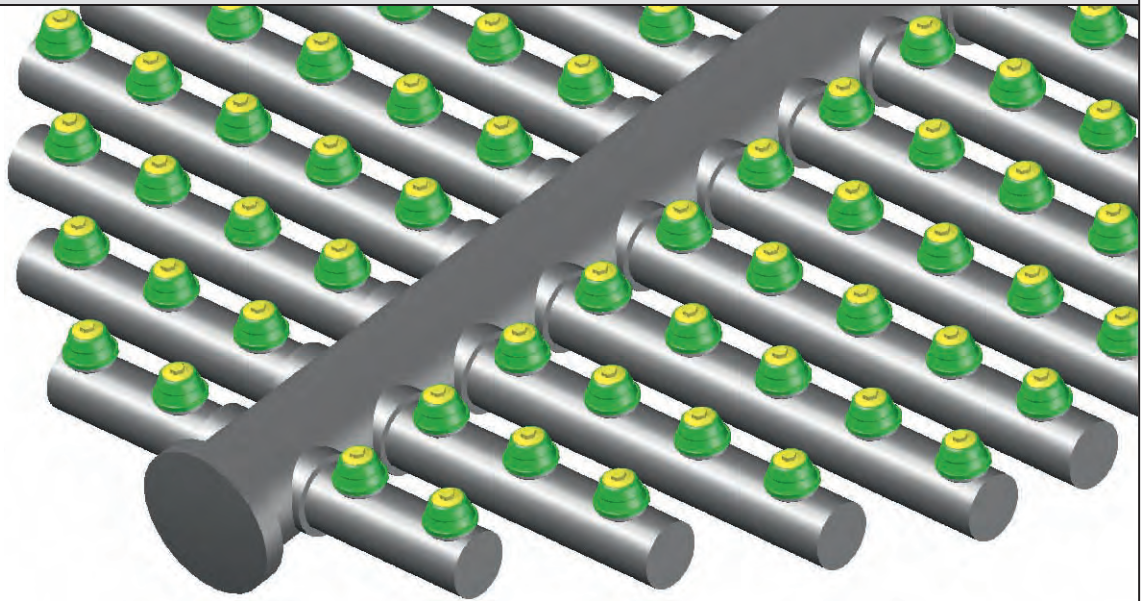

Typ ADSP

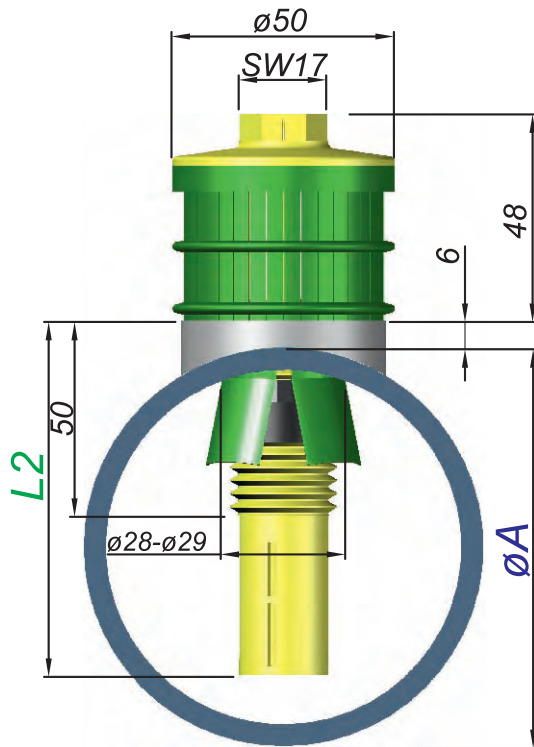

Typ AKSP

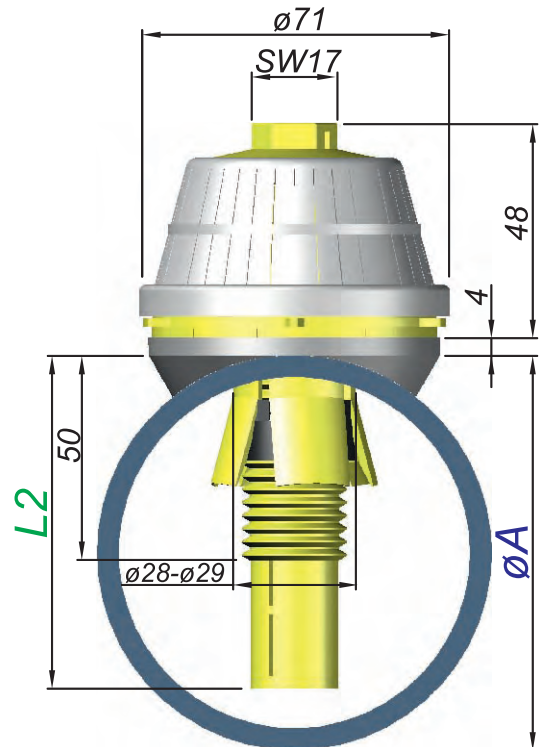

Bestellung Ordering Commande Encargo	Typ Type Type Tipa	Schlitz Slots Fentes Ranuras	$\varnothing A$	Schaft Shaft Longueur de tige Tija	L2	Bestellung Ordering Commande Encargo	Typ Type Type Tipa	Schlitz Slots Fentes Ranuras	$\varnothing A$	Schaft Shaft Longueur de tige Tija	L2
	ADSP	36 x 0,2 = 1,37 cm ² 36 x 0,3 = 2,05 cm ² 36 x 0,5 = 3,42 cm ² 36 x 1,0 = 6,84 cm ²	60,3 63 75 90 114 147 165 219 273 324	Nach Angabe according detail selon détails adecuado detalle			AKSP	40 x 0,2 = 1,95 cm ² 36 x 0,35 = 2,96 cm ² 20 x 0,5 = 2,35 cm ² 36 x 0,5 = 4,23 cm ² 20 x 0,8 = 3,78 cm ² 36 x 1,0 = 8,46 cm ² 24 x 1,5 = 7,05 cm ² 20 x 2,0 = 9,50 cm ²	60,3 63 75 90 114 147 165 219 273 324	Nach Angabe according detail selon détails adecuado detalle	

Filterdüsen für Drainagesystem

Filter-Nozzles for Drainage system

Système de drainage

Sistemas de drenaje

Montagebeispiel

Installation procedure

Exemple de montage

Ejemplo de montaje

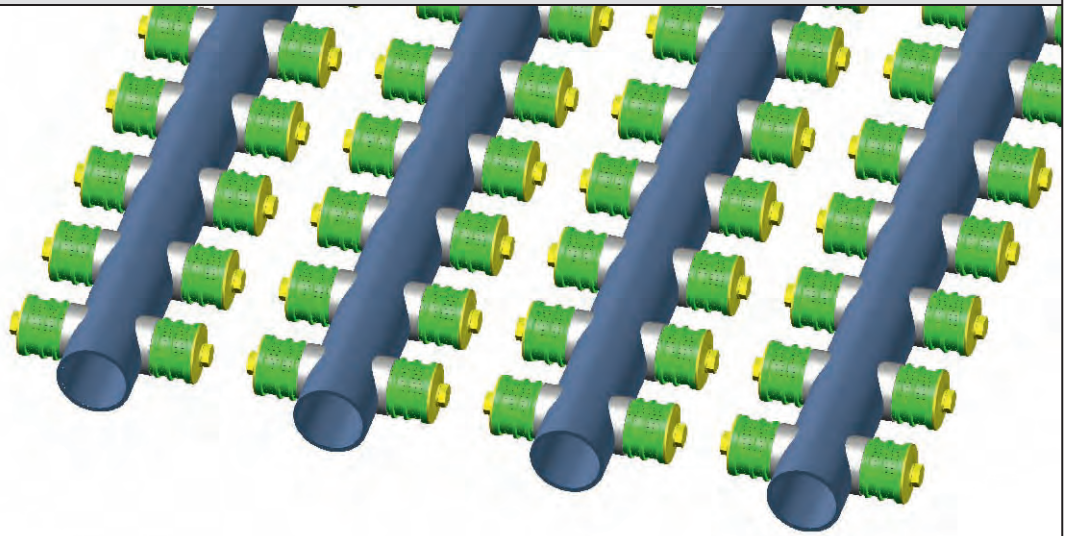

Typ DDR

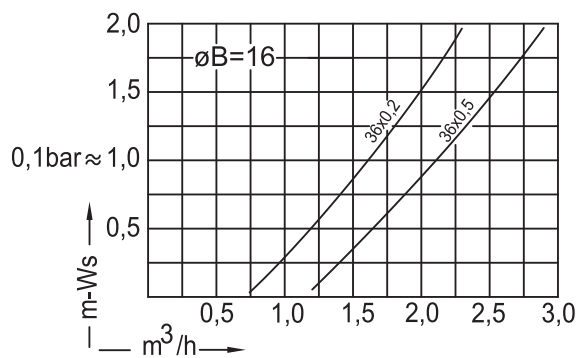
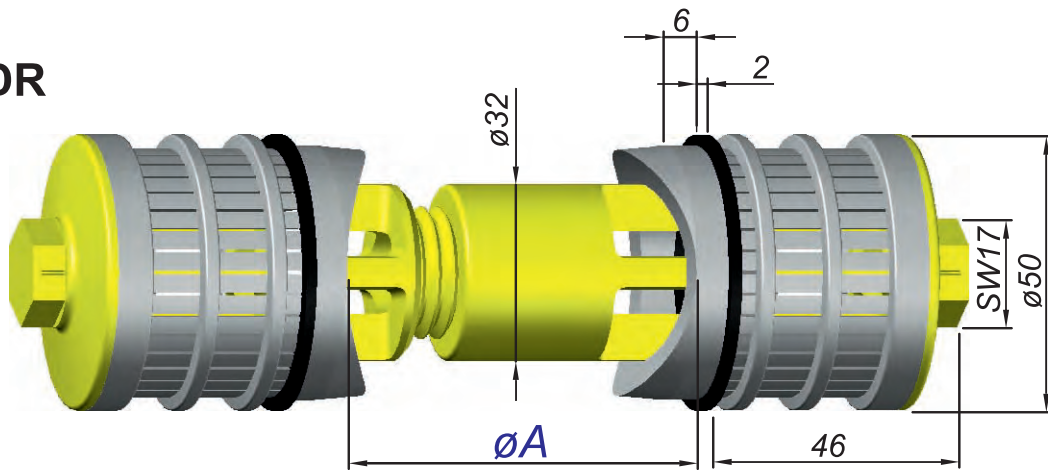

Bestellung Ordering Commande Encargo	Typ Type Type Tipa	Schlitze Slots Fentes Ranuras	øA
	DDR	24 x 0,2 = 0,91 cm ² 36 x 0,2 = 1,37 cm ² 36 x 0,3 = 2,05 cm ² 36 x 0,5 = 3,42 cm ² 12 x 0,8 = 1,82 cm ² 12 x 1,0 = 2,28 cm ² 24 x 1,0 = 4,56 cm ² 24 x 1,5 = 6,84 cm ² 20 x 2,0 = 7,00 cm ² 8 x 5,0 = 7,00 cm ²	60,3 ; 63 ; 75 ; 90 ; 114 ; 147 ; 165 ; 219 ; 273 ; 324

Filterdüsen für Drainagesystem	Filter-Nozzles for Drainage system	Système de drainage	Sistemas de drenaje
-----------------------------------	---------------------------------------	------------------------	------------------------

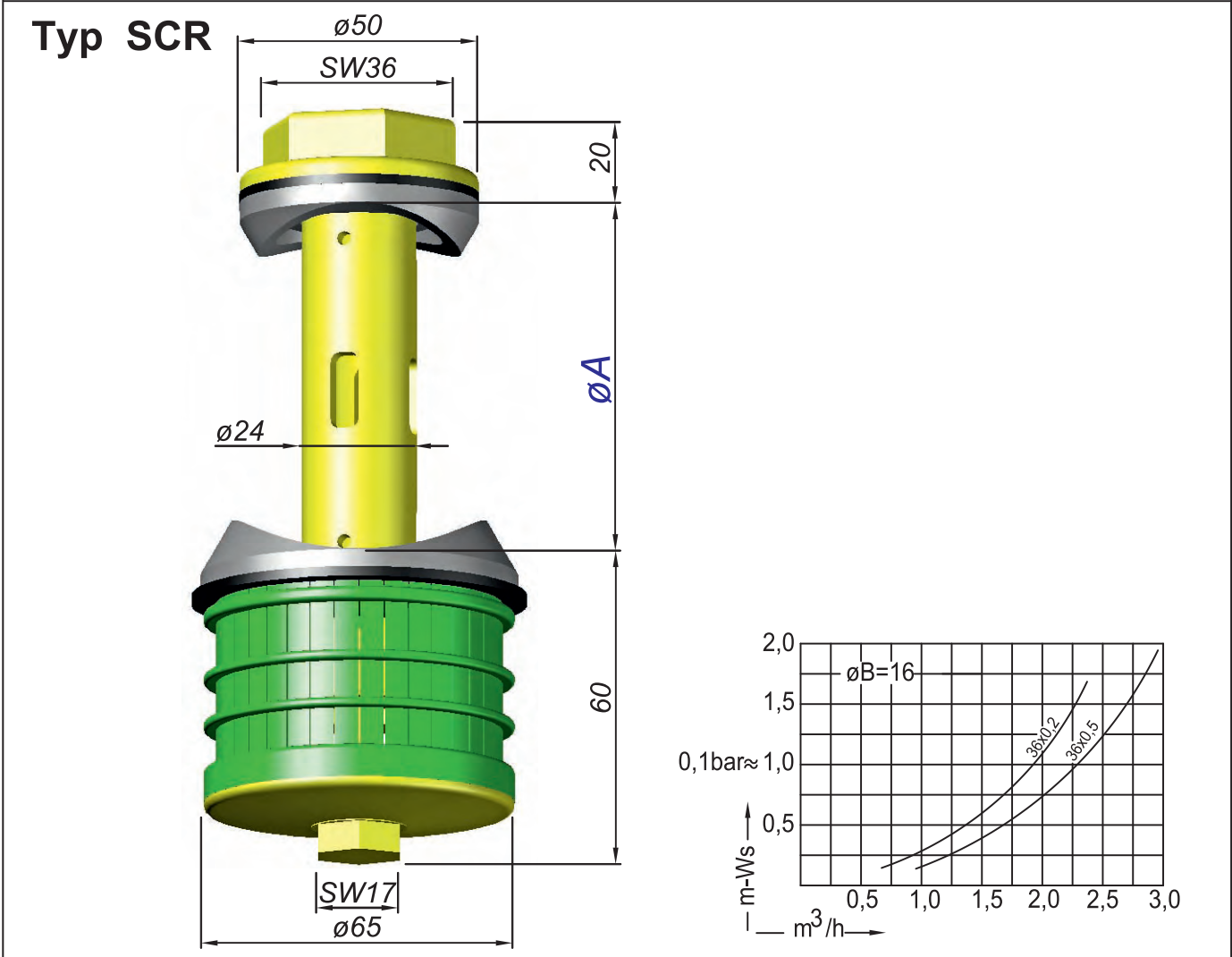

Bestellung Ordering Commande Encargo	Typ Type Type Tipa	Schlitze Slots Fentes Ranuras	øA
	SCR	36 x 0,2 = 1,95 cm ² 36 x 0,3 = 2,90 cm ² 36 x 0,5 = 4,90 cm ² 36 x 0,7 = 6,80 cm ² 36 x 1,0 = 9,80 cm ²	60,3 ; 63 ; 75 ; 90 ; 114 ; 147 ; 165 ; 219 ; 273 ; 324

Muttern und Scheiben	Nuts and Washers	Ecrous et joints	Tuerca y Arandela				
Typ MU43		Bestellung Ordering Commande Encargo	Typ Type Type Tipa	Gewinde Thread Filetage Rosca øA			
			MU43	1"WW M24 M22x1,5 M20	G1/2" G3/8"		
Typ MU60		Bestellung Ordering Commande Encargo	Typ Type Type Tipa	Gewinde Thread Filetage Rosca øA			
			MU60	1 1/4" WW 1"WW G 3/4" M24 M22x1,5 M20 M30			
Typ MUL60		Bestellung Ordering Commande Encargo	Typ Type Type Tipa	Gewinde Thread Filetage Rosca øA			
			MUL60	1 1/4" WW 1"WW G 3/4" M24 M22x1,5 M20			
Typ MUZ		Bestellung Ordering Commande Encargo	Typ Type Type Tipa	Gewinde Thread Filetage Rosca øA	øB		
			MUZ	M24	50		
				1 1/4"WW G 3/4" M24	60		
Typ MU84		Bestellung Ordering Commande Encargo	Typ Type Type Tipa	Gewinde Thread Filetage Rosca øA			
			MU84	G 2" G 1 1/2"			
Typ DP Typ DG		Bestellung Ordering Commande Encargo	Typ Type Type Tipa	øA	øB	S Material Material Materiu Material	
			DP	50	32; 30; 28; 25; 21 32; 25 32; 30; 25	2 5 7	PP
				70	32; 30; 28; 25; 21 32; 30; 28	2 7	
			DG	50 70 90	32; 28; 25; 21	2	EPDM (KTW)

Dübel	Expanding ring (dowel)	Douilles expansives	Anillas de expansion
-------	------------------------	---------------------	----------------------

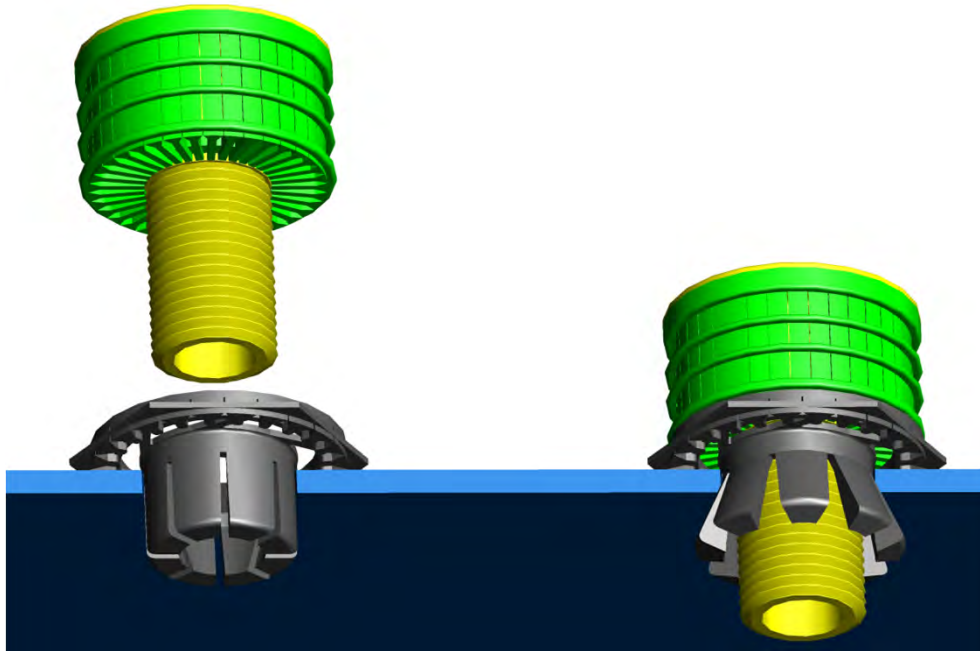

Typ DB50

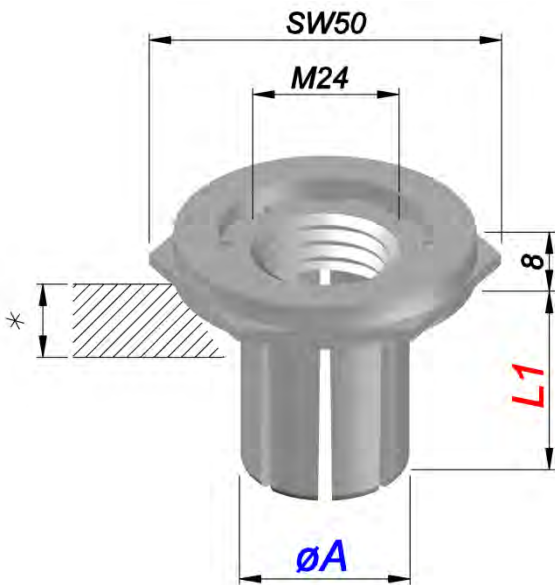

Typ DB65

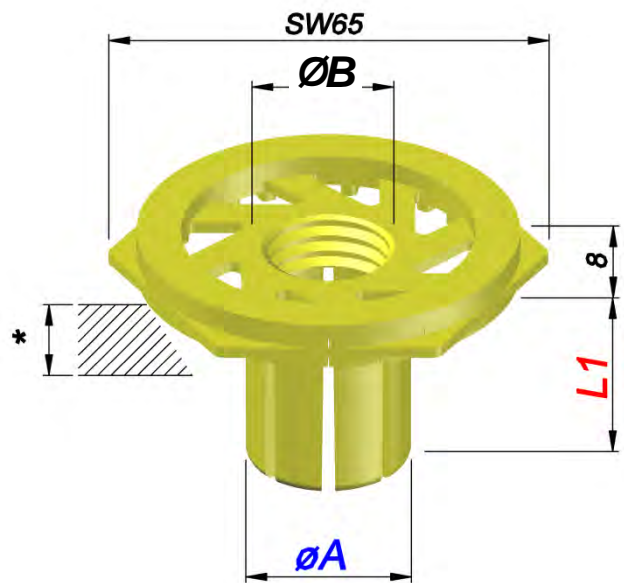

Bestellung Ordering Commande Encargo	Typ Type Type Tipa	øA	Bodenstärke plate thickness Epaisseur du plancher Espesor placa	*	L1	Bestellung Ordering Commande Encargo	Typ Type Type Tipa	øA	Bodenstärke plate thickness Epaisseur du plancher Espesor placa	*	øB	L1
✉	DB50	ø28	8 - 12	- elfenbein / ivory	36	✉	DB65	ø28	8 - 12	- elfenbein / ivory	M24	36
			12 - 17	- grau / grey								
			17 - 22	- schwarz / black								
			22 - 27	- blau / blue								
			8 - 12	- elfenbein / ivory				ø32	8 - 12	- elfenbein / ivory	M24	30
			12 - 17	- grau / grey								
			17 - 22	- schwarz / black								
			22 - 27	- blau / blue								
			8 - 12	- elfenbein / ivory				ø38	8 - 12	- elfenbein / ivory	1¼"ww	30
			12 - 17	- grau / grey								
			17 - 22	- schwarz / black								

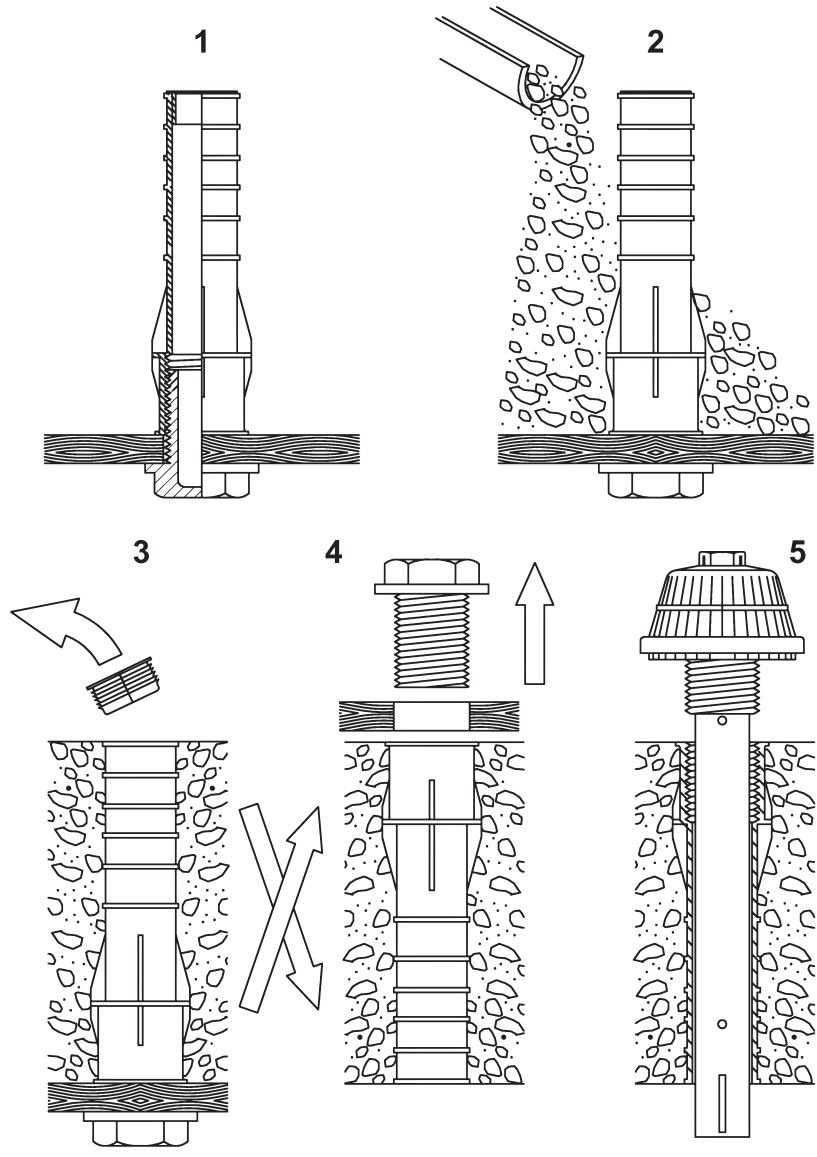
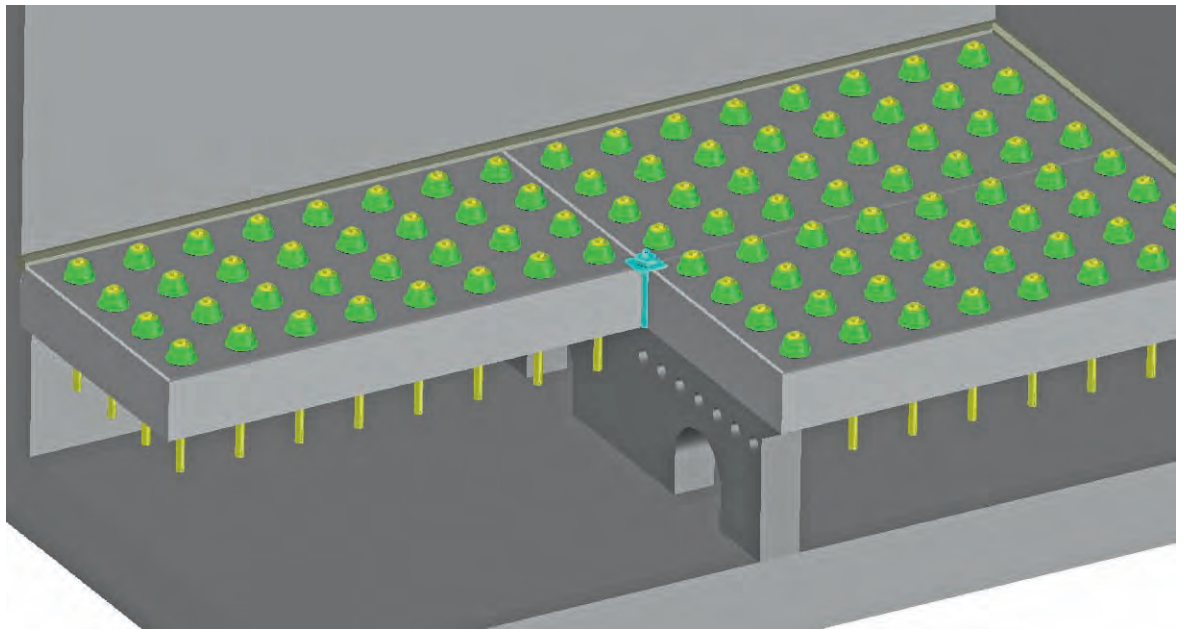

Buchsen für Beton- Filterböden	Sleeves for concrete - floors	Douilles et accessoires pour planchers béton	Casquillos para fondos de filtros de hormigon
--------------------------------------	-------------------------------------	--	---

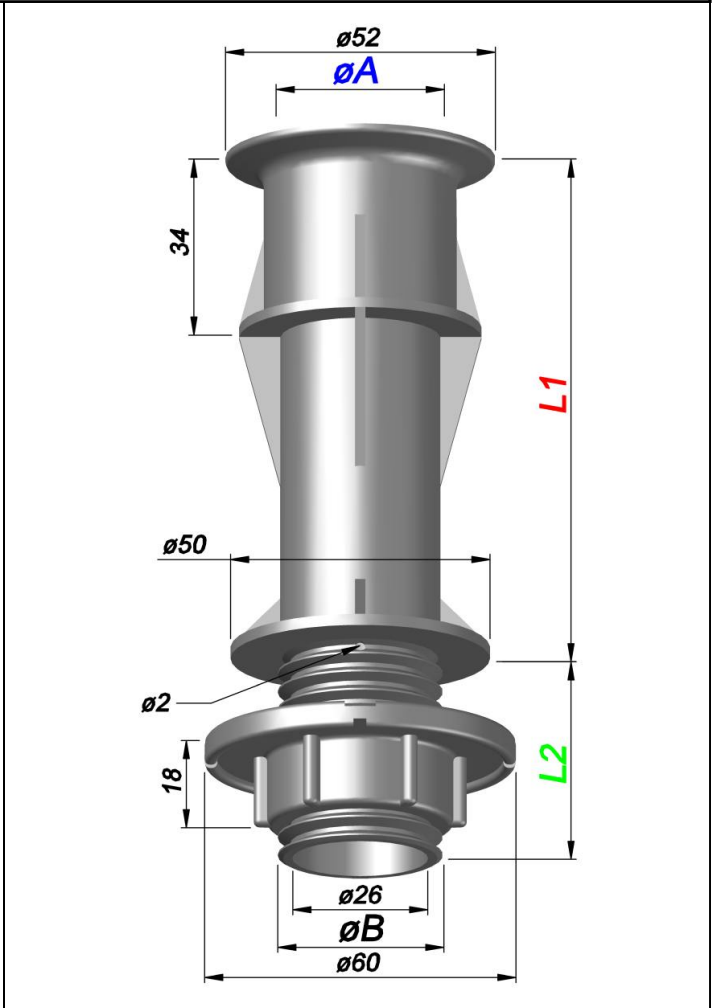
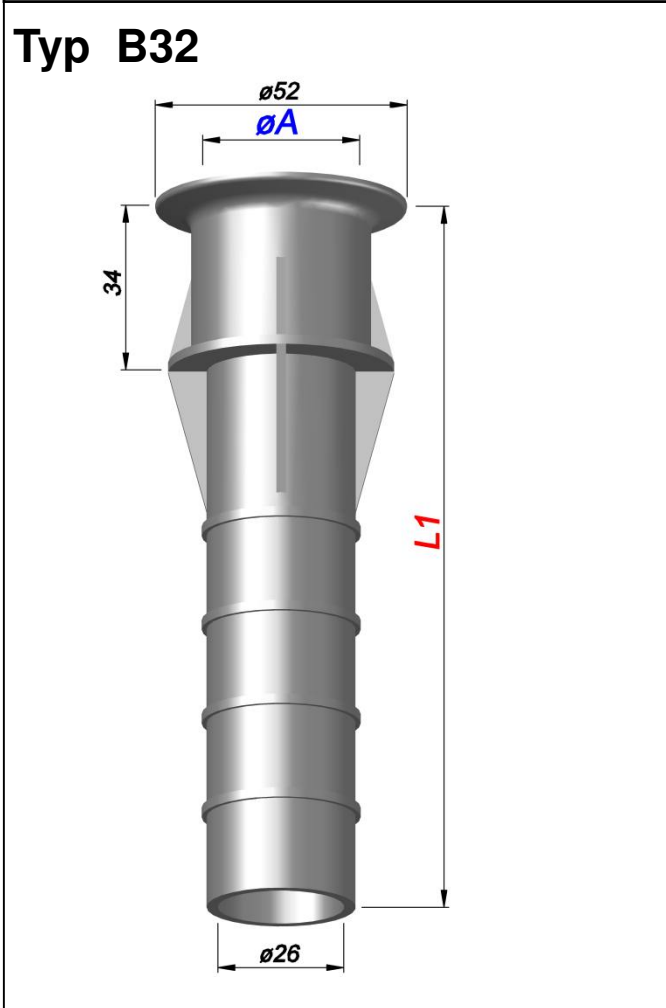

Bestellung Ordering Commande Encargo	Typ Type Type Tipa	Gewinde Thread Filetage Rosca	øA	L1	Bestellung Ordering Commande Encargo	Typ Type Type Tipa	Gewinde Thread Filetage Rosca	øA	øB	L1	L2
	B32	1 1/4"WW 1"WW				BM32	1 1/4"WW	1 1/4"WW	60, +10, +10,	40	

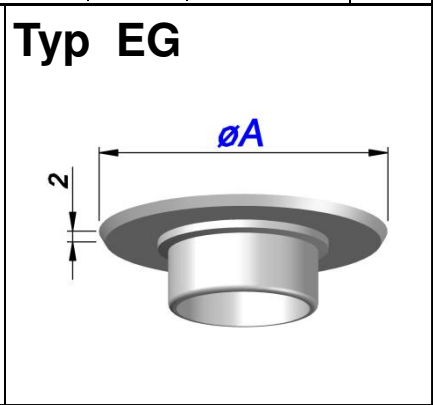
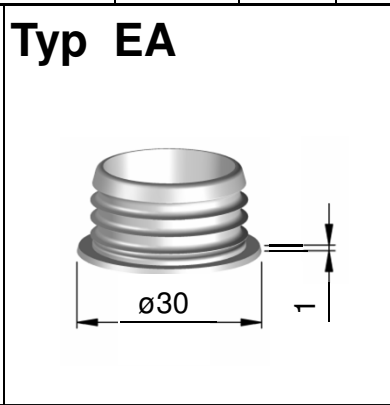
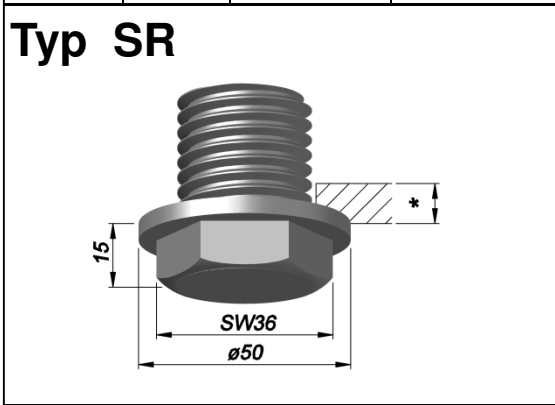

Bestellung Ordering Commande Encargo	Typ Type Type Tipa	Gewinde Thread Filetage Rosca	Bodenstärke plate thickness Epaisseur du plancher Espesor placa	*	Bestellung Ordering Commande Encargo	Typ Type Type Tipa	Bestellung Ordering Commande Encargo	Typ Type Type Tipa	øA
	SR	1 1/4"WW 1"WW G1" G3/4" M24	= mm			EA		EG50	54
								EG70	71

**Buchsen
für Rohre**

**Special lateral
sleeves**

**douilles pour tuyaux
et planchers béton**

**Casquillos
para tuberia**

Montagebeispiel

Installation
procedure

Exemple
de montage

Ejemplo
de montaje



Typ BR32

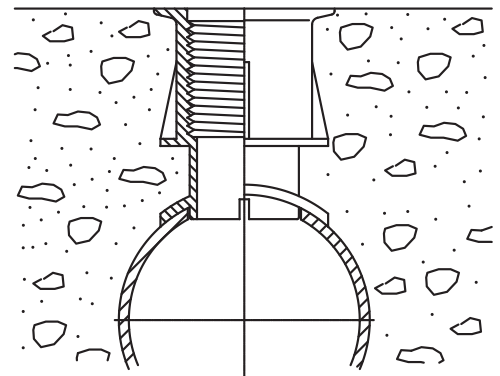
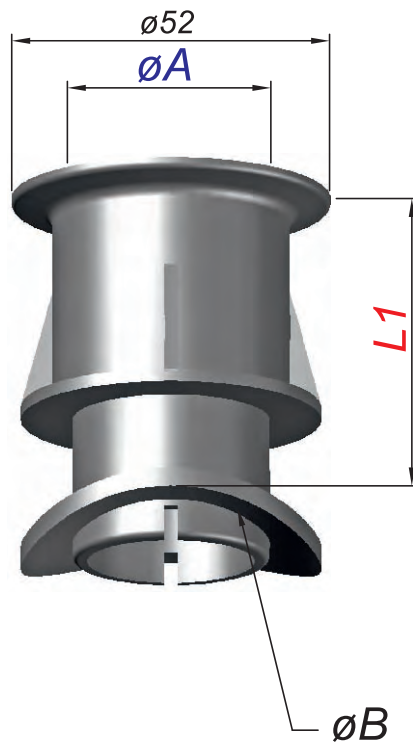

Bestellung Ordering Commande Encargo	Typ Type Type Tipa	L1	$\varnothing B$	Gewinde Thread Filetage Rosca	$\varnothing A$
	BR32	15	90; 110	1 1/4"WW	
		50	75; 90; 110; 324		

Anschluß-
armatur

Manifold
head

Raccord pour
bouteilles
échangeuses d'ions

Racor Adaptador
para Botellas de
intercambio Ionico

Typ ANA2



P max. 8 bar – 120 PSI

T max. 45°C – 110° F

Typ ANA2

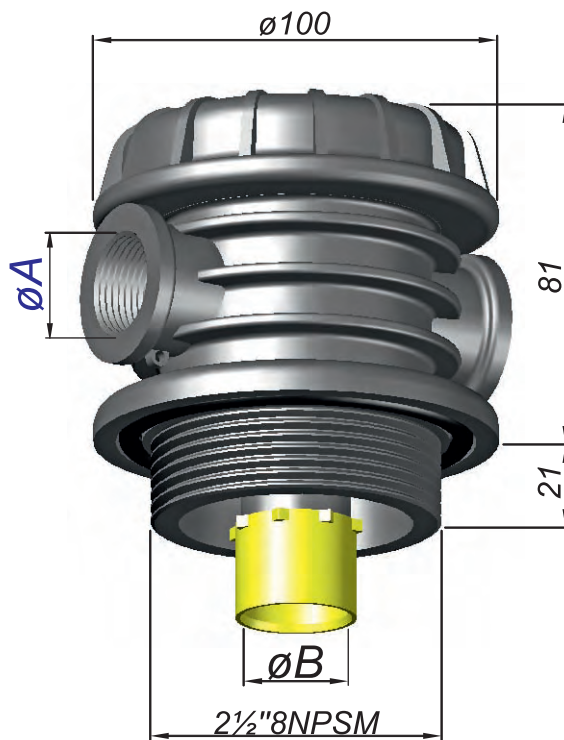

Bestellung Ordering Commande Encargo	Typ Type Type Tipa	$\varnothing A$	$\varnothing B = \text{mm}$	
✉	ANA2	1/4"NPT	1"	Ø 25,4
		G 3/4"	13/16	Ø 20,64
		3/4"NPT	1,05"	Ø 26,67
			25	Ø 25,2

Typ ANA-S



Bestellung Ordering Commande Encargo	Typ Type Type Tipa
✉	ANA-S

Typ ANA-K



Bestellung Ordering Commande Encargo	Typ Type Type Tipa
✉	ANA-K

Anschluß-
armatur

Manifold
head

Raccord pour
bouteilles
échangeuses d'ions

Racor Adaptador
para Botellas de
intercambio Ionico

Typ ANA2-QD



P max. 8 bar – 120 PSI

T max. 45°C – 110° F

Typ ANA2-QD

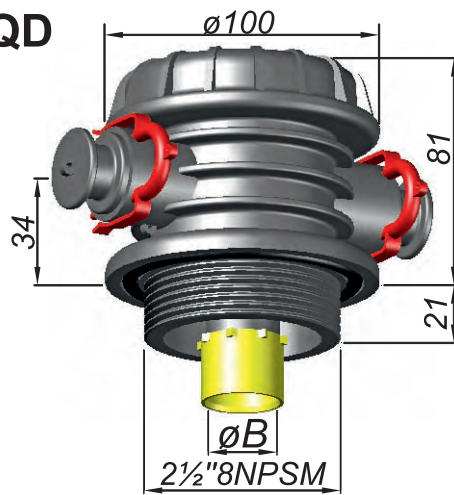

Bestellung Ordering Commande Encargo	Typ Type Type Tipa	$\varnothing B = \text{mm}$	
	ANA2-QD	1"	$\varnothing 25,4$
		13/16	$\varnothing 20,64$
		1,05"	$\varnothing 26,67$
		25	$\varnothing 25,2$

Typ QD-G3/4"

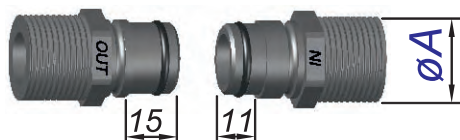

Bestellung Ordering Commande Encargo	Typ Type Type Tipa
	QD-G3/4"

Typ QDHE

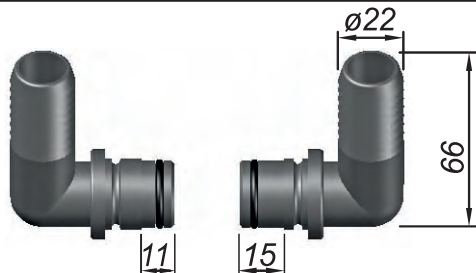

Bestellung Ordering Commande Encargo	Typ Type Type Tipa
	QDHE

Typ ANA-S



Bestellung Ordering Commande Encargo	Typ Type Type Tipa
	ANA-S

Typ ANA-K

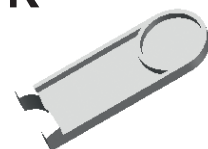

Bestellung Ordering Commande Encargo	Typ Type Type Tipa
	ANA-K

Anschluß-
armatur

Manifold
head

Raccord pour
bouteilles
échangeuses d'ions

Racor Adaptador
para Botellas de
intercambio Ionico

Typ ANA3

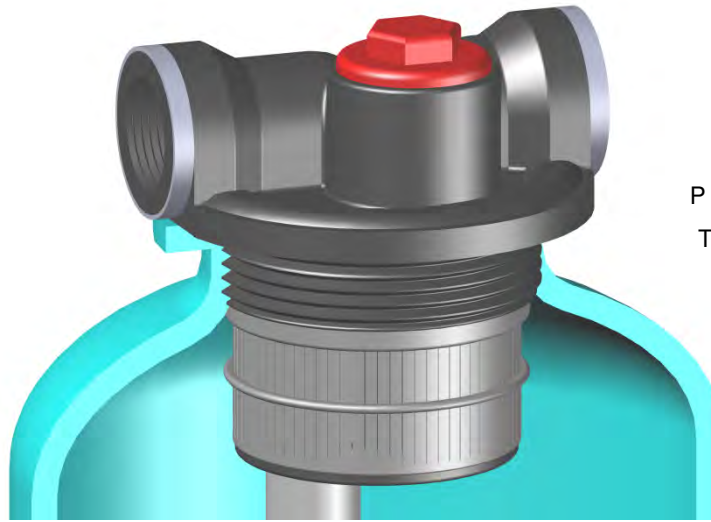

P max. 8 bar – 120 PSI

T max. 45°C – 110°F

Typ ANA3

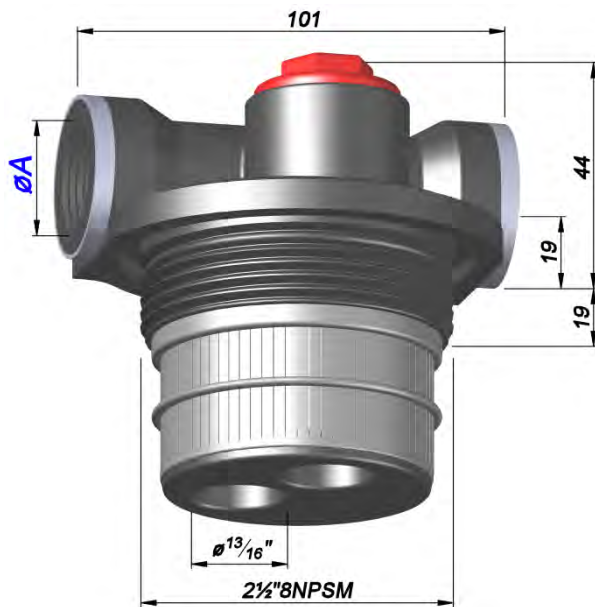

Typ RA-L

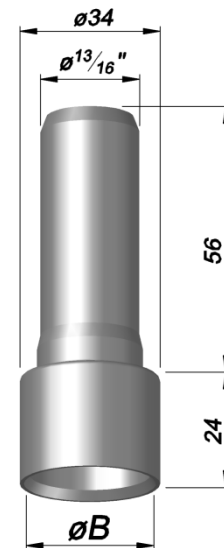

Bestellung Ordering Commande Encargo	Typ Type Type Tipa	ØA	Schlitze Slots Fentes Ranuras
	ANA3	G 3/4" 3/4"NPT	0,2 0,3 0,5

Bestellung Ordering Commande Encargo	Typ Type Type Tipa	ØB = mm
	RA-L	25 Ø 25,2

Filterdüsen-
für Düsenstab

Filter-Nozzles
for Distributor

Crépines pour
distributeur

Toberas
de distribucion

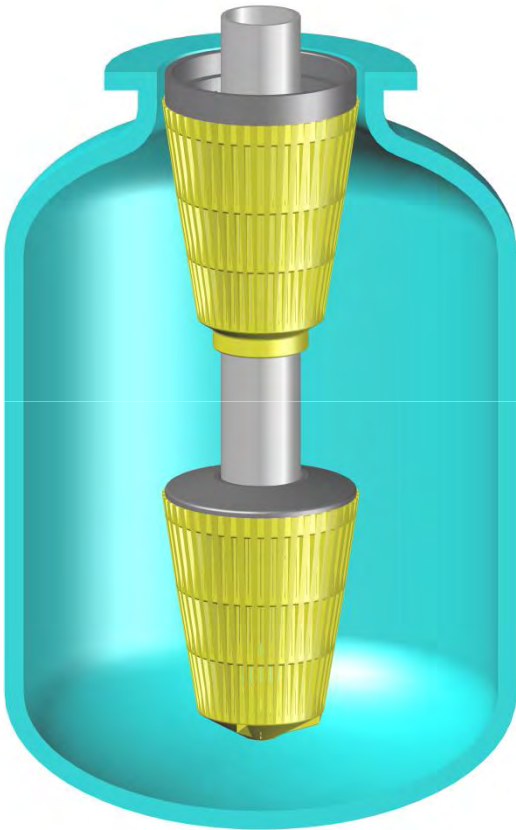

Typ GDO

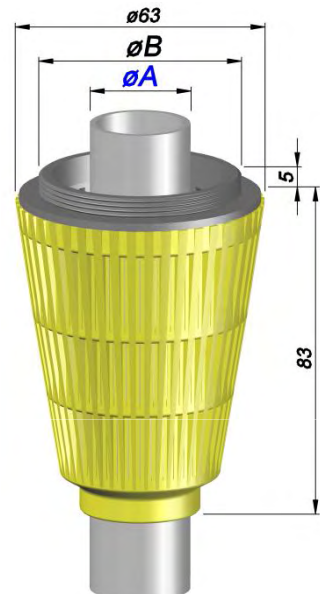

Bestellung Ordering Commande Encargo	Typ Type Type Tipa	Schlitze Slots Fentes Ranuras	ϕB	ϕA	=mm
✉	GDO	0,2 = 5,22cm ²	2"20	32	$\phi 32$
			$\phi 60,5$	13/16	$\phi 20,64$
			$\phi 60$	1"	$\phi 25,4$
			QD	1,05"	$\phi 26,67$
				25	$\phi 25,2$

Typ GDUK

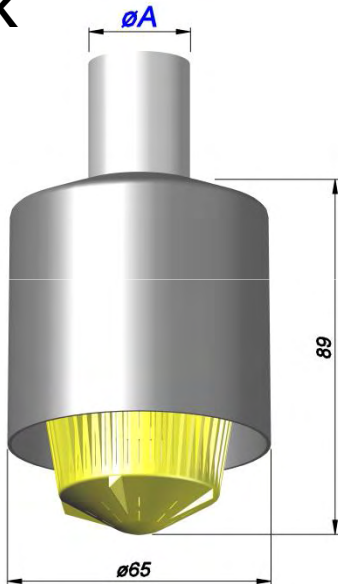

Typ GDU

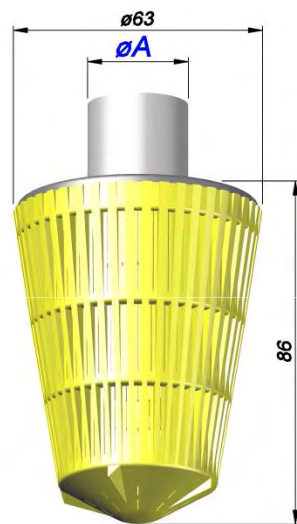

Bestellung Ordering Commande Encargo	Typ Type Type Tipa	Schlitze Slots Fentes Ranuras	ϕA	=mm
✉	GDU	0,2 = 5,22cm ²	1"	$\phi 25,4$
			13/16	$\phi 20,64$
			1,05"	$\phi 26,67$
			25	$\phi 25,2$
			1/2"	$\phi 21,4$
	GDUK			

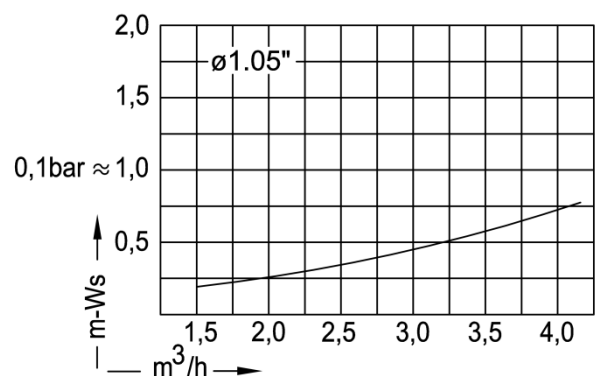

**Filterdüsen-
für Düsenstab**

**Filter-Nozzles
for Distributor**

**Crépines pour
distributeur**

**Toberas
de distribucion**

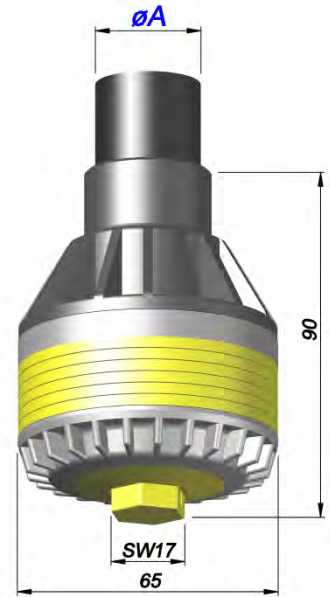
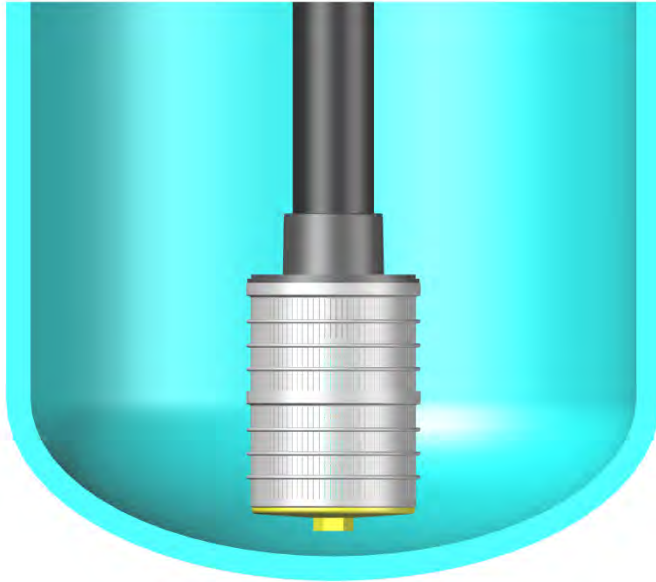

Bestellung Ordering Commande Encargo	Typ Type Type Tipa	Schlitze Slots Fentes Ranuras	$\varnothing A$
	GLU	0,2 0,3 0,5	3/4"NPT $\varnothing 24,4$

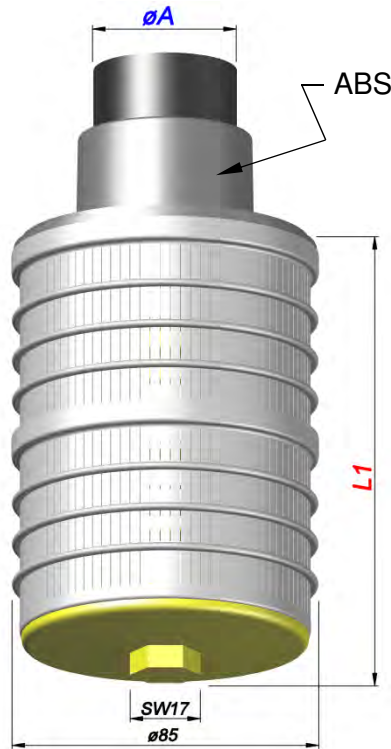
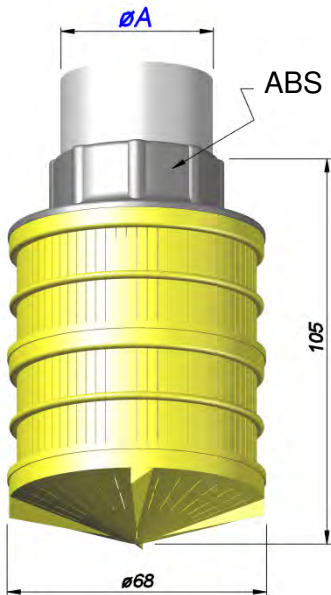

Bestellung Ordering Commande Encargo	Typ Type Type Tipa	Schlitze Slots Fentes Ranuras	$\varnothing A$	Bestellung Ordering Commande Encargo	Typ Type Type Tipa	Schlitze Slots Fentes Ranuras	$\varnothing A$	Länge Length Longueur Largura	$L1$	Bestellung Ordering Commande Encargo	Typ Type Type Tipa	Schlitze Slots Fentes Ranuras	$\varnothing A$
	GWU	0,2 = 6,91 cm ² 0,3 = 11,03 cm ² 0,5 = 17,94 cm ²	$\varnothing 32$ $\varnothing 40$		GRU	0,2 0,5	$\varnothing 40$ $\varnothing 50$ $\varnothing 63$	73 ; 126			GCU	0,2 0,3 0,5	3/4"NPT $\varnothing 24,4$

**Entleerungs-
Entnahme-Filterdüsen**

**Drain-
Nozzles**

**Crépines
de drainage**

**Toberas
de drenaje**

Montagebeispiel

Installation
procedure

Exemple
de montage

Ejemplo
de montaje



Typ EDK

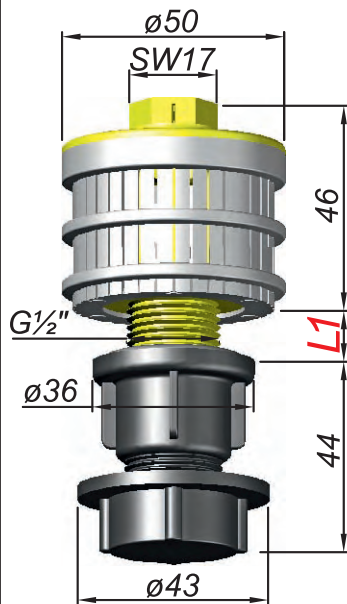

Typ ED

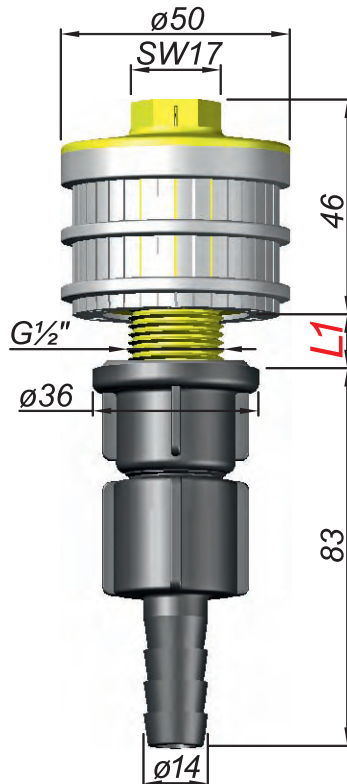

Typ EHK

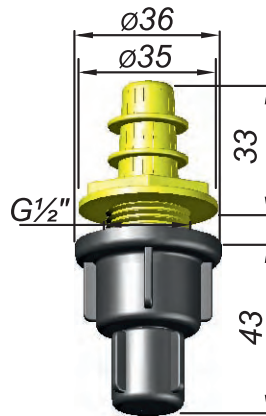

Typ EH

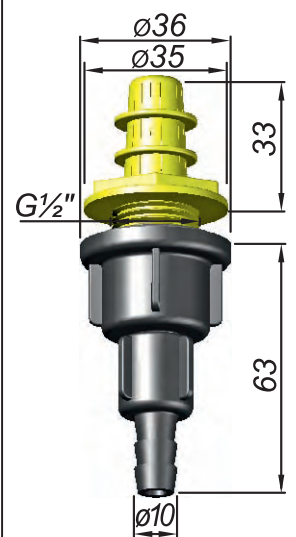

Bestellung Ordering Commande Encargo	Typ Type Type Tipa	Schlitze Slots Fentes Ranuras
---	-----------------------------	--

Bodenstärke Plate thickness Epaisseur du plancher Espesor placa	L1
--	-----------

Bestellung Ordering Commande Encargo	Typ Type Type Tipa
---	-----------------------------

Bestellung Ordering Commande Encargo	Typ Type Type Tipa
---	-----------------------------

	ED EDK	36 x 0,2 = 1,37 cm ² 36 x 0,5 = 3,42 cm ²
--	-------------------	--

Nach Angabe
according detail
selon détails
adecuado detalle

	EHK-0,2
--	----------------

	EH-0,2
--	---------------

**Entleerungs-
Entnahme-Filterdüsen**

**Drain-
Nozzles**

**Crépines
de drainage**

**Toberas
de drenaje**

Typ E

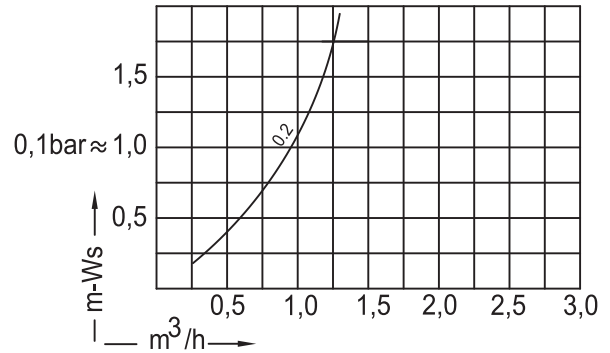
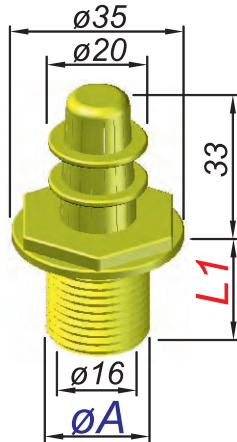

Bestellung Ordering Commande Encargo	Typ Type Type Tipa	Schlitz Slots Fentes Ranuras	Gewinde Thread Filetage Rosca	Gewindelänge Thread length Longueur de filetage Largura de la rosca
	E	0,2 = 1,0cm²	G 1/2"	8
			G 3/4"	17

Typ E2

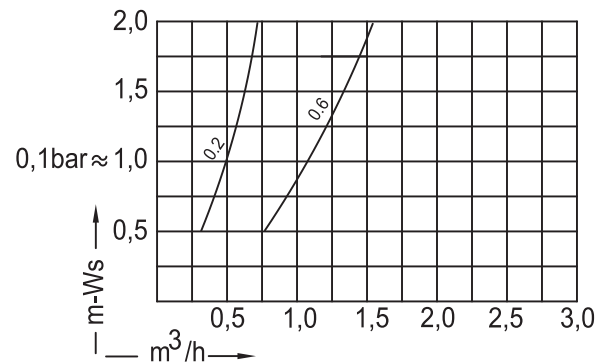
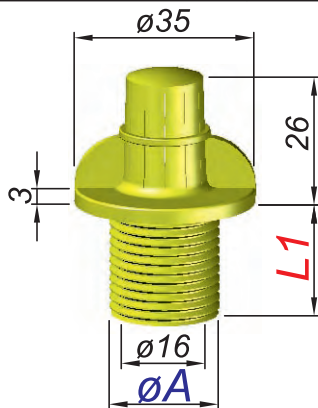

Bestellung Ordering Commande Encargo	Typ Type Type Tipa	Schlitz Slots Fentes Ranuras	Gewinde Thread Filetage Rosca	Gewindelänge Thread length Longueur de filetage Largura de la rosca
	E2	0,2 = 0,28cm²	G 1/2"	22
		0,6 = 0,84cm²	7/8"WW	16

Typ ES10



Bestellung Ordering Commande Encargo	Typ Type Type Tipa	Schlitz Slots Fentes Ranuras	$\varnothing A$
	ES10	0,2	6
			8
			10

Verteiler

distributor

Distributeur

Distribuidor

Montagebeispiel

Installation
procedure

Exemple
de montage

Ejemplo
de montaje



Typ OV

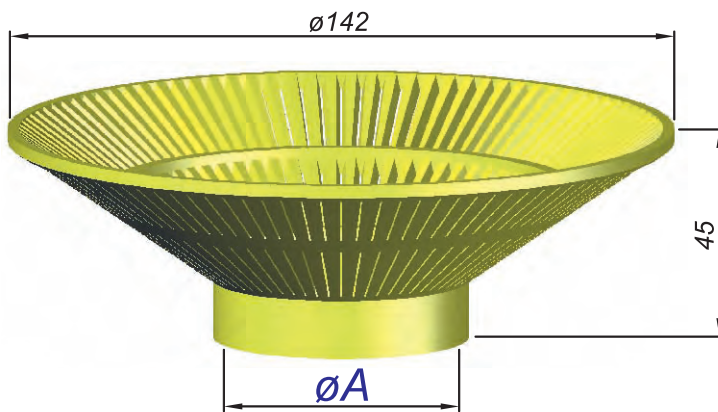

Bestellung Ordering Commande Encargo	Typ Type Type Tipa	Schlitze Slots Fentes Ranuras	$\varnothing A$
	OV	0,25	$\varnothing 1,9''$ $\varnothing 50$

Typ UV

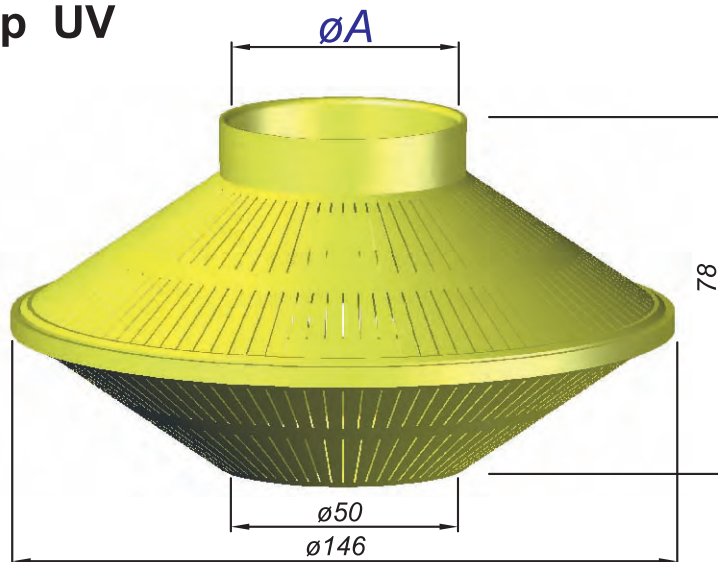

Bestellung Ordering Commande Encargo	Typ Type Type Tipa	Schlitze Slots Fentes Ranuras	$\varnothing A$
	UV	0,25 = 17,96 cm ²	$\varnothing 1,9''$ $\varnothing 50$

Obere Verteiler

Top distributor

Distributeur supérieur

Distribuidor superior

R2P

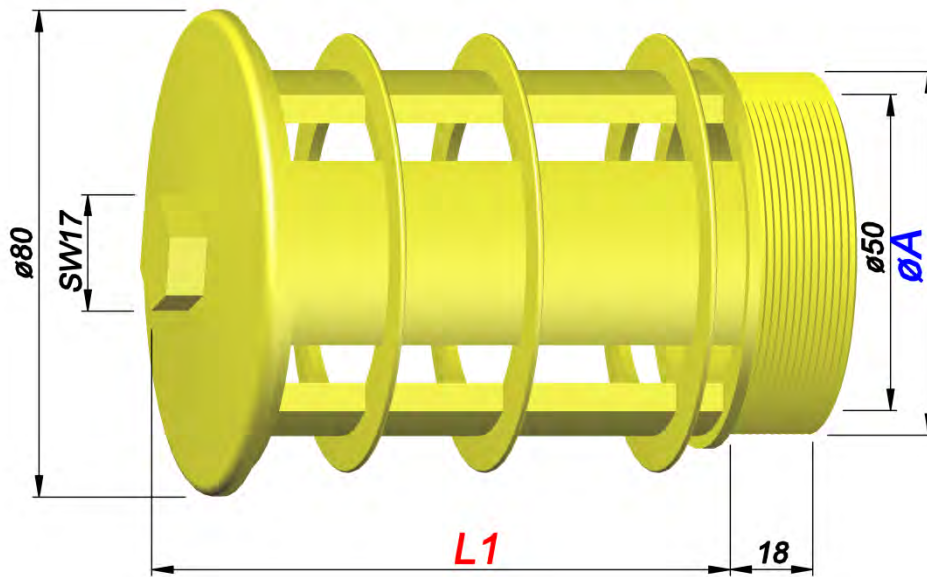

Bestellung Ordering Commande Encargo	Type Type Type Tipa	Gewinde Thread Filetage Rosca øA	Gewindelänge Thread length Longueur de filetage Largura de la rosca L1
	R2P	G 2"	42, 95, 155

R3P

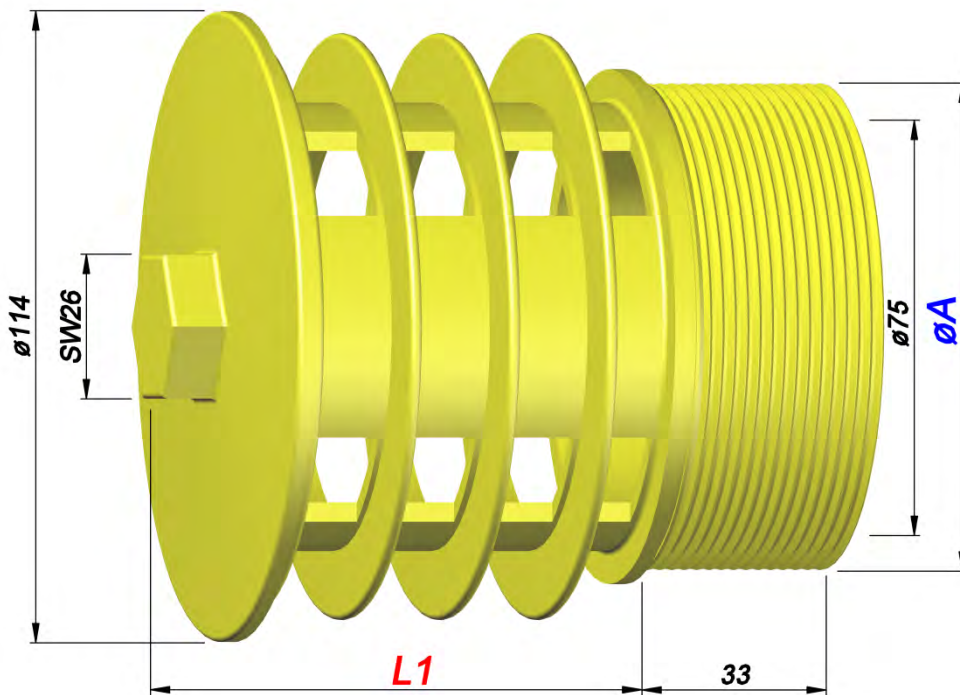

Bestellung Ordering Commande Encargo	Type Type Type Tipa	Gewinde Thread Filetage Rosca øA	Länge Length Longueur Largura L1
	R3P	G 3" 3" NPT 4" 8UN	96, 168, 240

Filterdüsen

Filter-Nozzles

Crépines à filtre

Toberas filtrantes

Typ R2

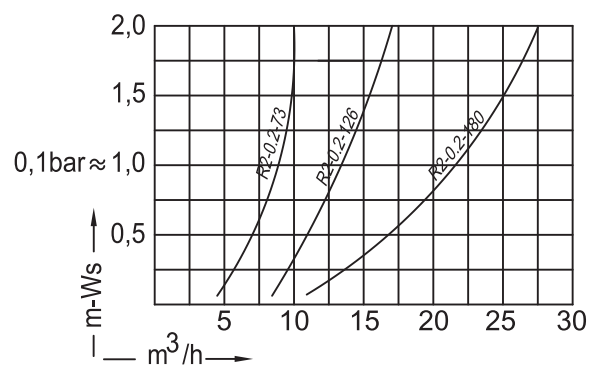
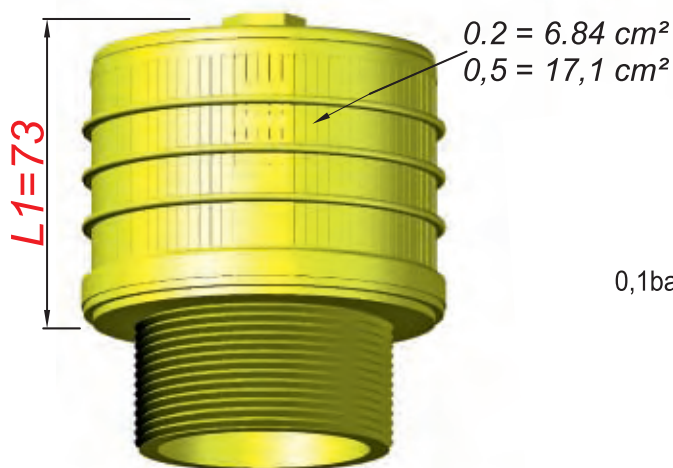
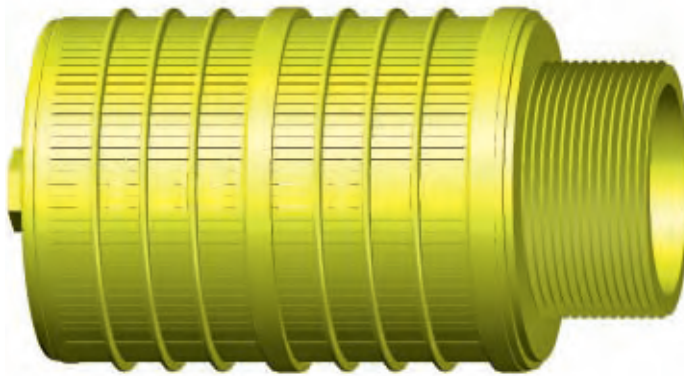
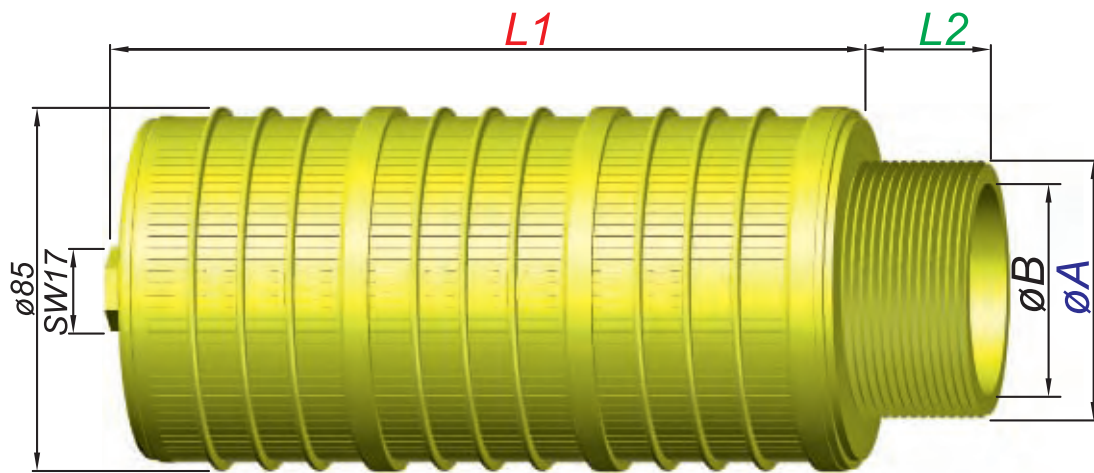

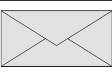
Bestellung Ordering Commande Encargo	Typ Type Type Tipa	Schlitze Slots Fentes Ranuras	$\varnothing A$	$\varnothing B$	$L2$	Kopflänge Headlength Longueur de tête Longitude de la cabeza
	R2	0,2	G 2"	$\varnothing 50$	30, 55	L1
		0,3	G 1½"	$\varnothing 38$	30, 55	
		0,5	G 2"	1 1/4"NPT	30	
		1,0	G 2"	1 1/2"NPT	30	
			$\varnothing 68$	G 2"	30	
			1 1/2"NPT	1 1/4"NPT	30	
			2 ½" 8NPSM	$\varnothing 60$	20	
73, 126, 180, 231, 284, 338, 389, 442, 496, 547, 600, 654, 705, 758, 812, 863, 916, 970, 1021, 1074, 1128, 1179, 1232, 1286						

Typ R3

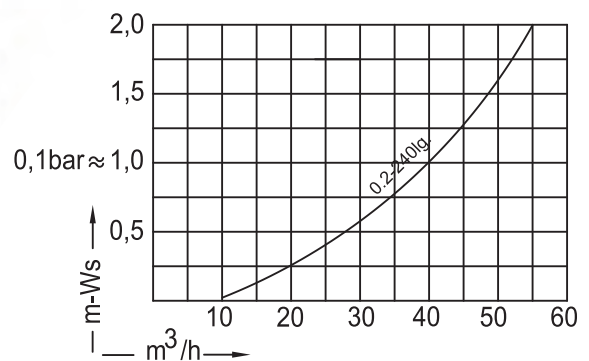
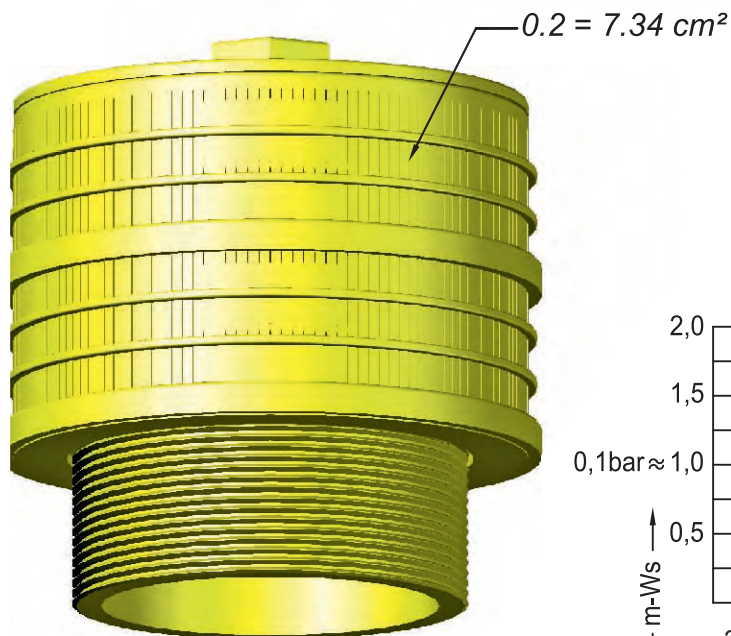
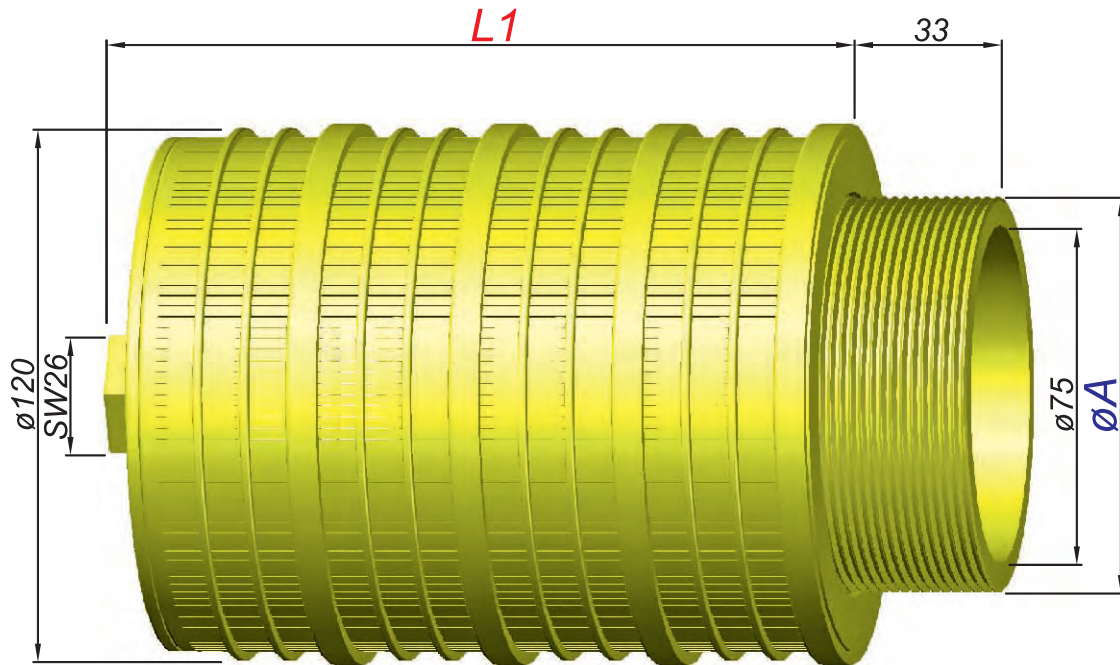

Bestellung Ordering Commande Encargo	Typ Type Type Tipa	Schlitze Slots Fentes Ranuras	ØA	Kopflänge Headlength Longueur de tête Longitude de la cabeza	L1
	R3	0,2 0,5	G 3" 3"NPT 4" 8UN	168, 240, 312, 384, 456, 528, 600, 672, 744, 816, 888, 960, 1032, 1104, 1176, 1248, 1320 ...	

**Filterdüsen-
Arme**

**Filter-Nozzles
Arms**

Crépines bras

**Brazos de toberas
a filtro**

Typ A

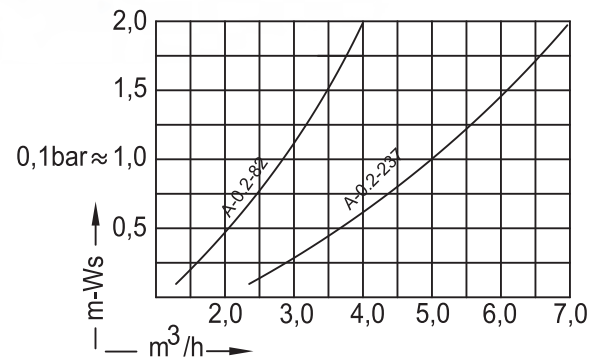
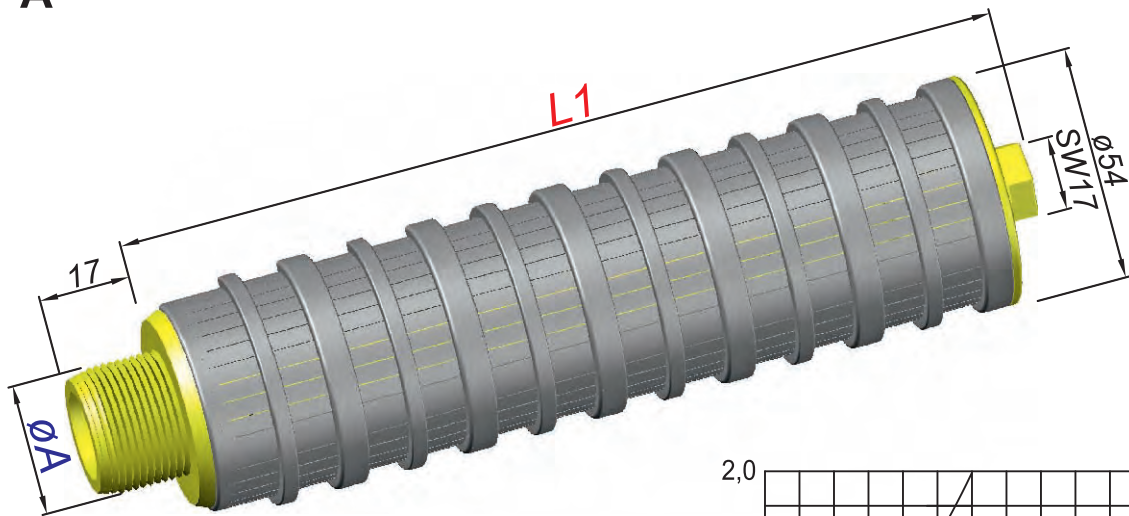

Bestellung Ordering Commande Encargo	Typ Type Type Tipa	Schlitze Slots Fentes Ranuras	Gewinde Thread Filetage Rosca	øA
	A	0,2 0,5 1,0 2,0	M30x2 3/4"NPT G 3/4" G 1"	

A	SG6	SK6	SO6	SO8	SK8	SK6F	SK8F
Länge Length Longueur Largura	L1						
	ø = mm						
82	259	258	258				
113	321	316	316				
144	383	374	374				
175	445	432	432				
206	507	491	491	520	520	491	520
237	569	549	549	580	580	549	580
268	631	607	607	640	640	607	640
299	693	665	665	699	699	665	699
330	755	724	724	759	759	724	759
361	817	782	782	819	819	782	819
392	879	840	840	879	879	840	879
423	941	898	898	939	939	898	939
454	1003	957	957	999	999	957	999
485	1065	1015	1015	1059	1059	1015	1059
516	1127	1073	1073	1119	1119	1073	1119
547	1189	1131	1131	1179	1179	1131	1179
578	1251	1189	1189	1239	1239	1189	1239
609	1313	1247	1247	1299	1299	1247	1299
640				1359	1359	1305	1359
671				1419	1419	1363	1419
702				1479	1479	1421	1479
733				1539	1539	1479	1539
764				1599	1599	1537	1599
795				1659	1659	1595	1659

Filterdüsen-Sterne
mit 6 Armen

Filter-Nozzles-Stars
with 6 arms

Crépines
étoiles
à 6 bras

Estrellas para
toberas a filtro
con 6 brazos

Typ SG6

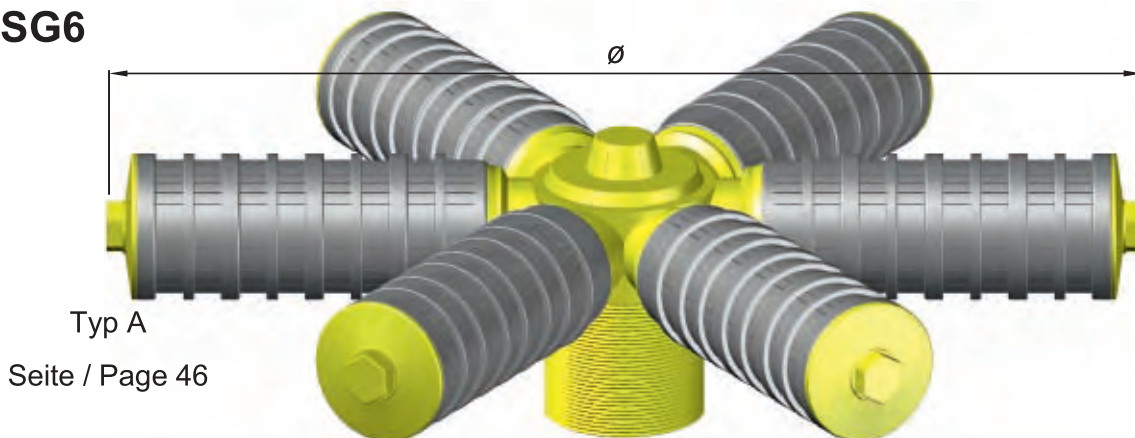

Typ MSG6

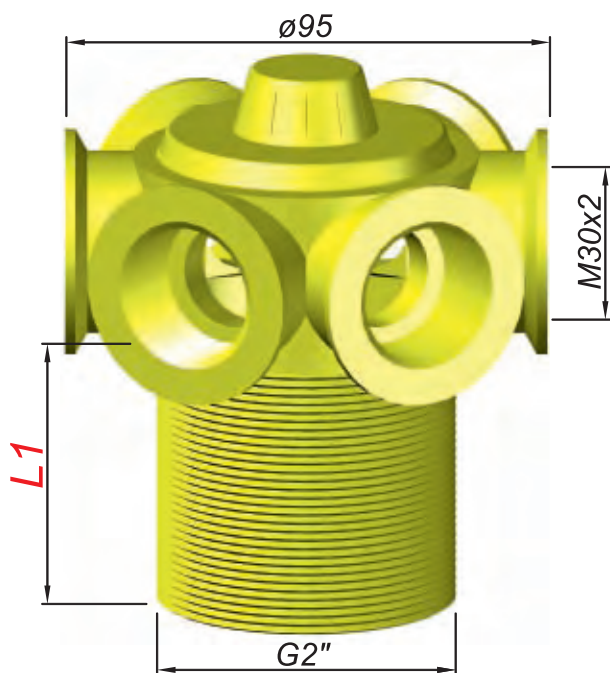

Typ ER

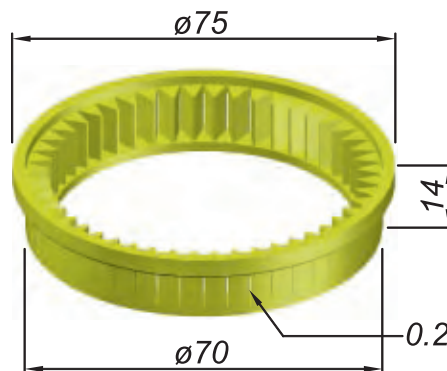

Bestellung Ordering Commande Encargo	Typ Type Type Tipa
	ER

Bestellung Ordering Commande Encargo	Typ Type Type Tipa	L1
	MSG6	25 55

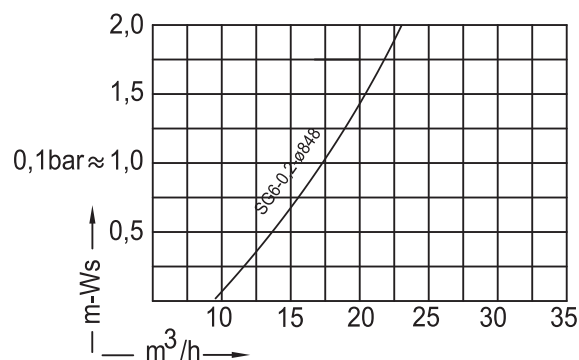

Filterdüsen-Sterne
mit 6 Armen

Filter-Nozzles-Stars
with 6 arms

Crépines
étoiles
à 6 bras

Estrellas para
toberas a filtro
con 6 brazos

Typ SK6

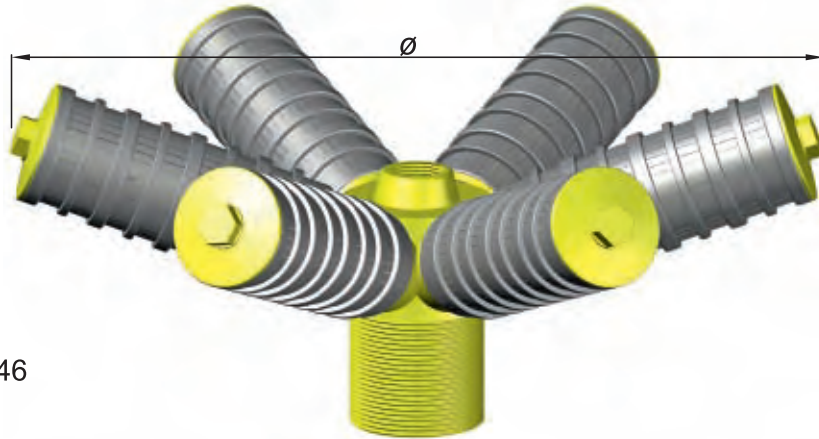

Typ A

Seite / Page 46

Typ MSK6

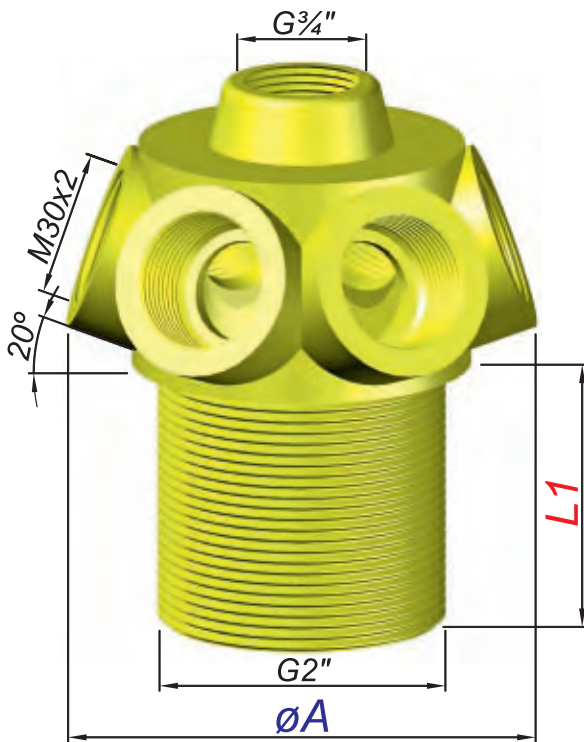

Typ ER

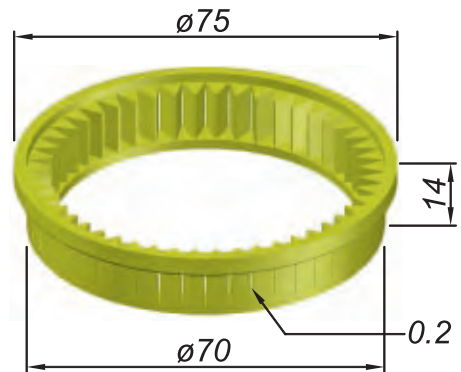

Bestellung Ordering Commande Encargo	Typ Type Type Tipa
---	-----------------------------

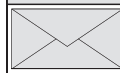

ER

Bestellung Ordering Commande Encargo	Typ Type Type Tipa	L1	$\varnothing A$
	MSK6	55	98 110

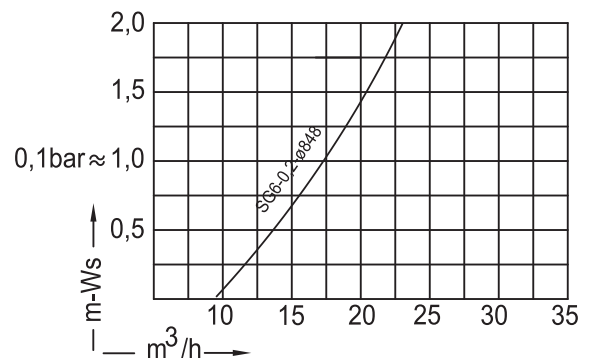

Filterdüsen-Sterne
mit 6 Armen

Filter-Nozzles-Stars
with 6 arms

Crépines
étoiles
à 6 bras

Estrellas para
toberas a filtro
con 6 brazos

Typ SO6

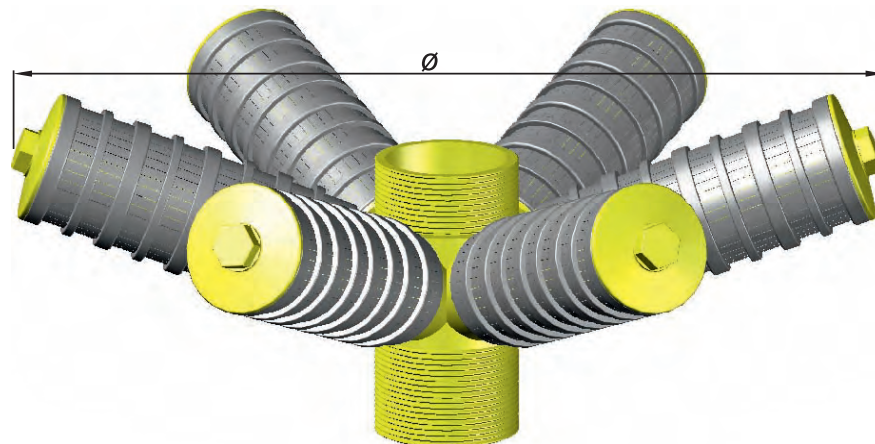

Typ A

Seite / Page 46

Typ MSO6

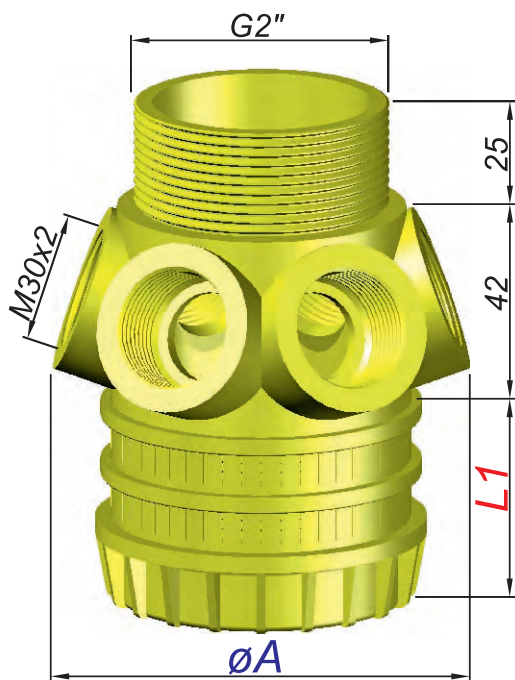

Typ MSO60

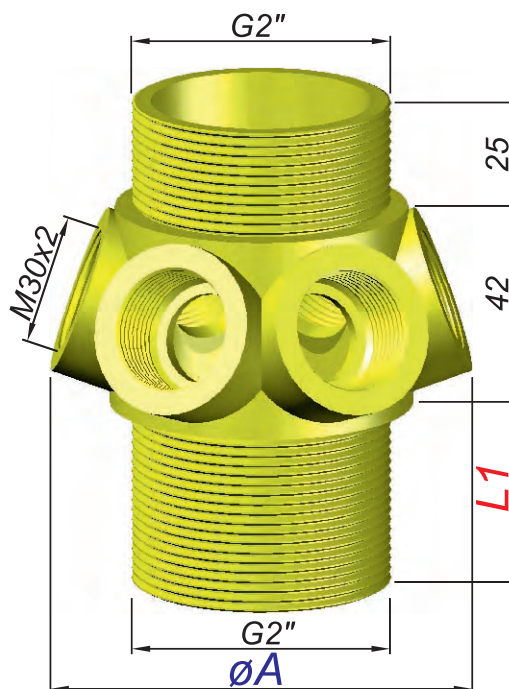

Bestellung Ordering Commande Encargo	Typ Type Type Tipa	L1	$\emptyset A$
	ER	25	98
		50	110

Bestellung Ordering Commande Encargo	Typ Type Type Tipa	L1	$\emptyset A$
	MSO6	20	98 110
	MSO61	34	
	MSO62	46	
	MSO63	58	

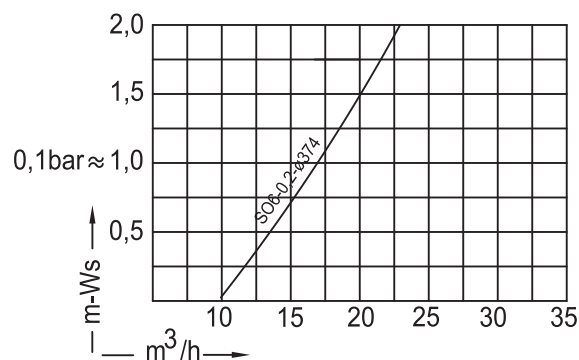

**Filterdüsen-Sterne
mit 8 Armen**

**Filter-Nozzles-Stars
with 8 arms**

**Crépines
étoiles
à 8 bras**

**Estrellas para
toberas a filtro
con 8 brazos**

Typ SO8

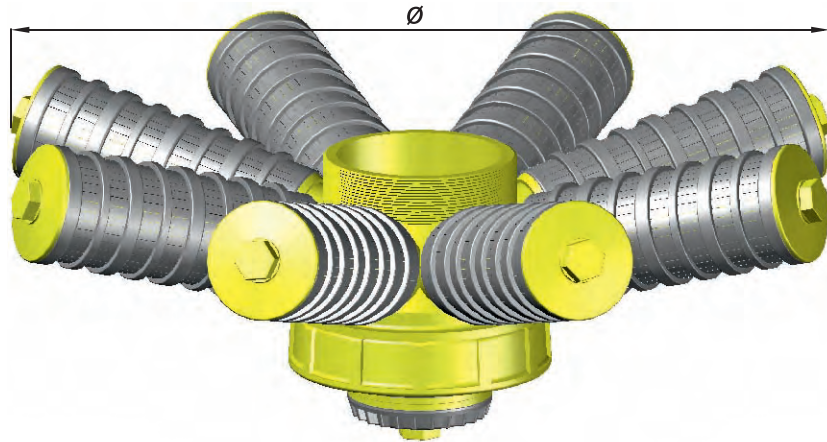

Typ A

Seite / Page 46

Typ MSO8

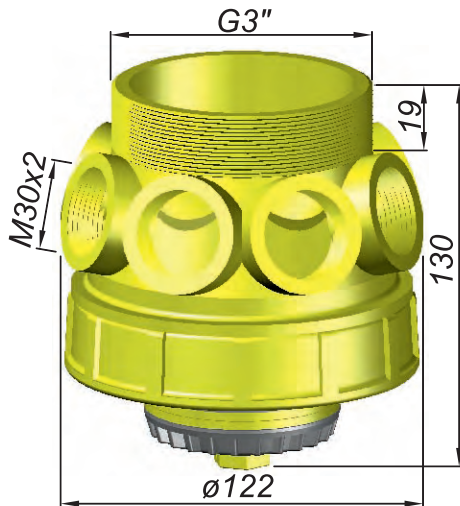

Typ MSO16

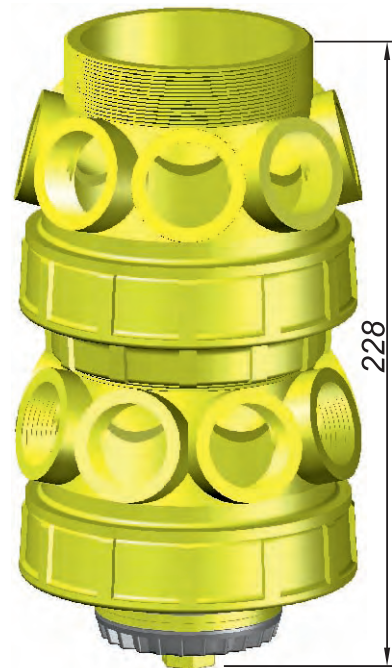

Bestellung Ordering Commande Encargo	Typ Type Type Tipa
	MSO8

Bestellung Ordering Commande Encargo	Typ Type Type Tipa
	MSO16

Typ GR3"

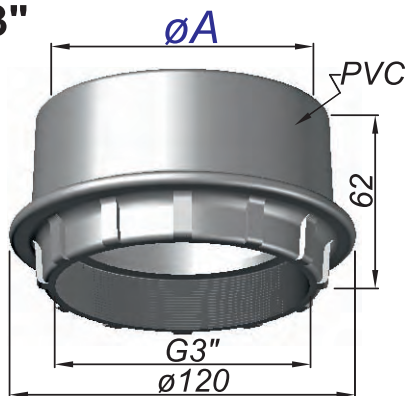

Bestellung Ordering Commande Encargo	Typ Type Type Tipa	øA
	GR3"	90

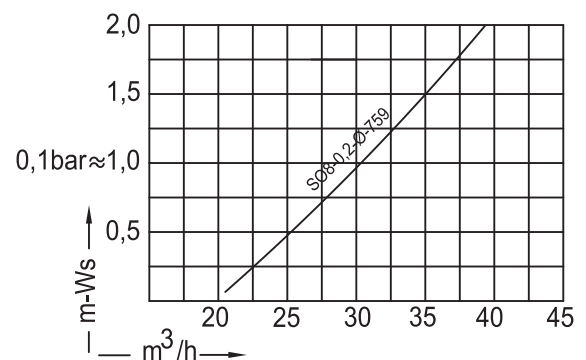

**Filterdüsen-Sterne
mit 8 Armen**

**Filter-Nozzles-Stars
with 8 arms**

**Crépines
étoiles
à 8 bras**

**Estrellas para
toberas a filtro
con 8 brazos**

Typ SK8

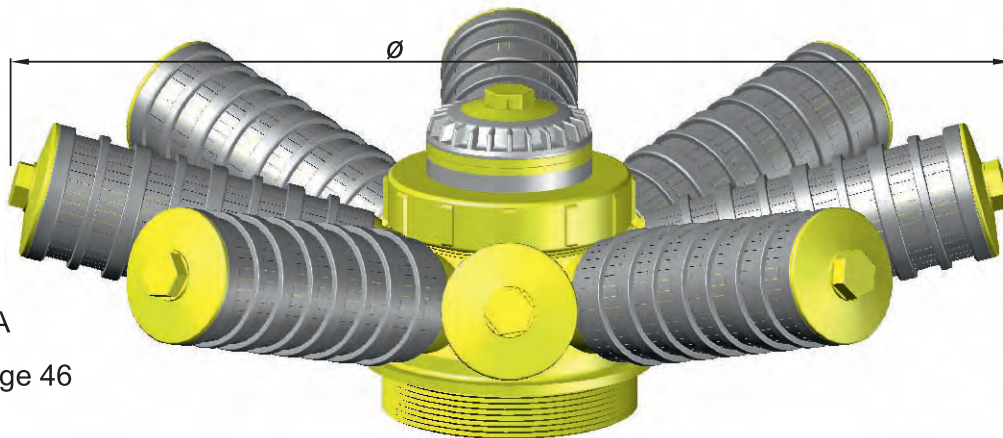

Typ A

Seite / Page 46

Typ MSK8

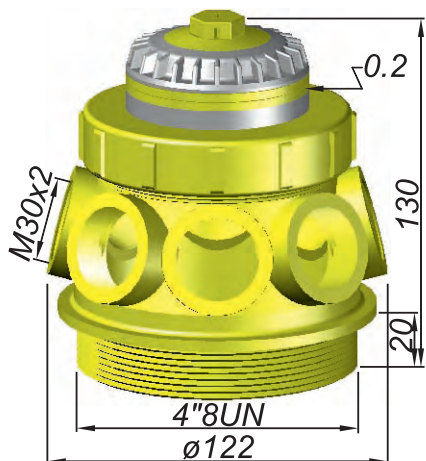

Bestellung Ordering Commande Encargo	Typ Type Type Tipa
	MSK8

Typ MSK16



Bestellung Ordering Commande Encargo	Typ Type Type Tipa
	MSK16

Typ GR4"-3"

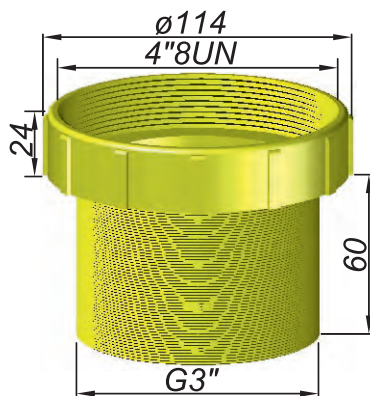

Bestellung Ordering Commande Encargo	Typ Type Type Tipa
	GR4"-3"

Typ ER3

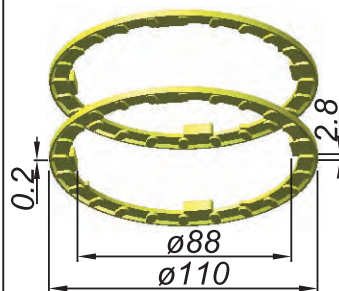

Bestellung Ordering Commande Encargo	Typ Type Type Tipa
	ER3

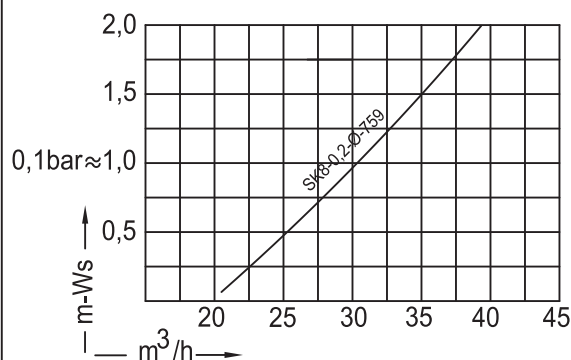

**Filterdüsen-Sterne
mit 8 Armen
für Flanschtank**

**Filter-Nozzles-Stars
with 8 arms
for Flange tank**

**Crépines étoiles
à 8 bras**

**Estrellas para
toberas a filtro
con 8 brazos**

Typ SK8F

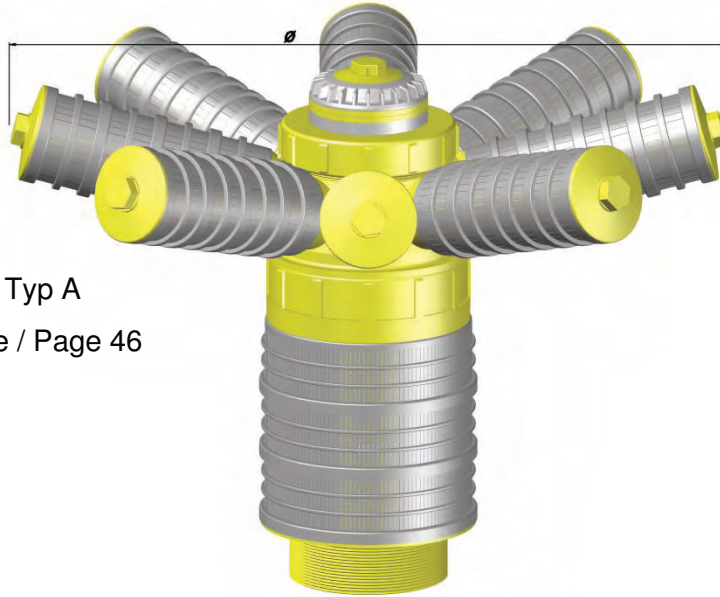

Typ A

Seite / Page 46

Typ MSK8F



Typ MSK16F

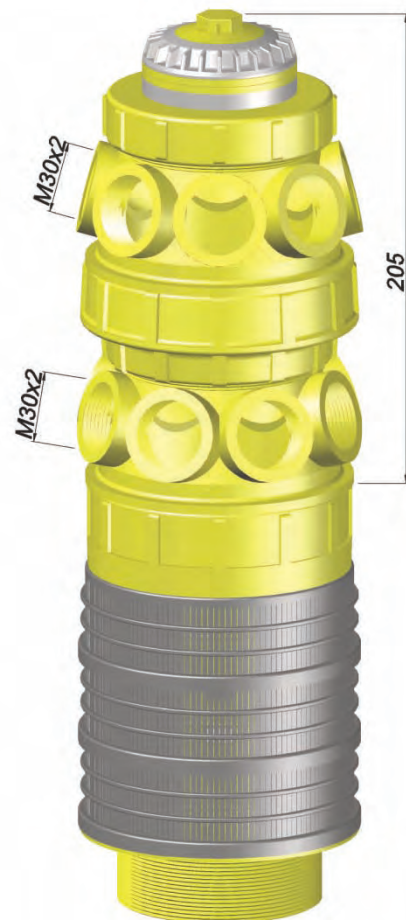

Bestellung Ordering Commande Encargo	Typ Type Type Tipa	Schlitz Slots Fentes Ranuras	$\varnothing A$	Länge Length Longueur Largura
✉	MSK8F	0,2	G 3"	115,
			3"NPT	150,
			4" 8UN	190,
				228

Bestellung Ordering Commande Encargo	Typ Type Type Tipa
✉	MSK16F

Adapter und
Verbinder

Adapter and
Connector

Adaptateur
et raccord

Adaptador
y conector

Typ GR2"

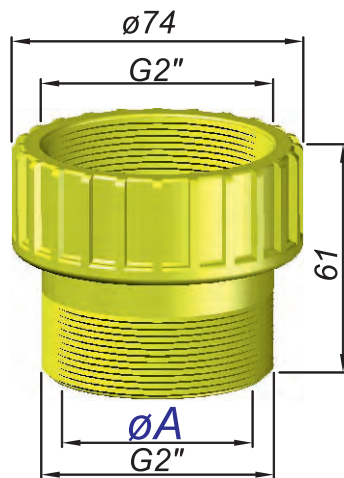

Bestellung Ordering Commande Encargo	Typ Type Type Tipa	Gewinde Thread Filetage Rosca	øA
	GR2"	G 1 1/2" G 1 1/4"	

Typ GR2"

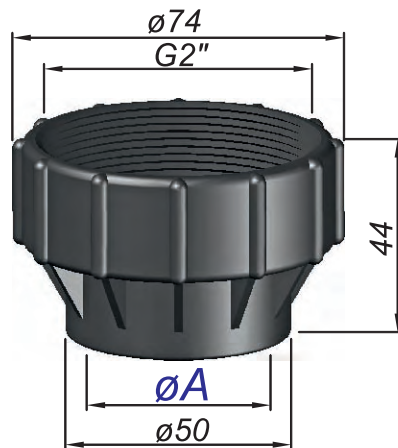

Bestellung Ordering Commande Encargo	Typ Type Type Tipa	Gewinde Thread Filetage Rosca	øA
	GR2"	ø 40 ø 50 ø60,3 ø63	PVC

Typ GR3"

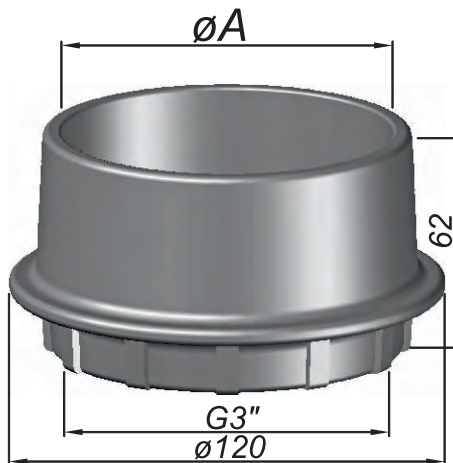

Bestellung Ordering Commande Encargo	Typ Type Type Tipa	Gewinde Thread Filetage Rosca	øA
	GR3"	ø 90 3" (US)	PVC

Adapter und Verbinder	Adapter and Connector	Adaptateur et raccord	Adaptador y conector
-----------------------	-----------------------	-----------------------	----------------------

Typ GR4“

Bestellung Ordering Commande Encargo	Typ Type Type Tipa	Gewinde Thread Filetage Rosca	øA
	GR4“	G 3“	

Typ GR4“

Bestellung Ordering Commande Encargo	Typ Type Type Tipa	Gewinde Thread Filetage Rosca	øA
	GR4“	G 2“	

Typ VB4“

Bestellung Ordering Commande Encargo	Typ Type Type Tipa	Gewinde Thread Filetage Rosca	øA
	VB4“	G 3“	

Drainage-
system

Drainage
system

Système de
drainage

Systema de
drenaje

Typ SD3

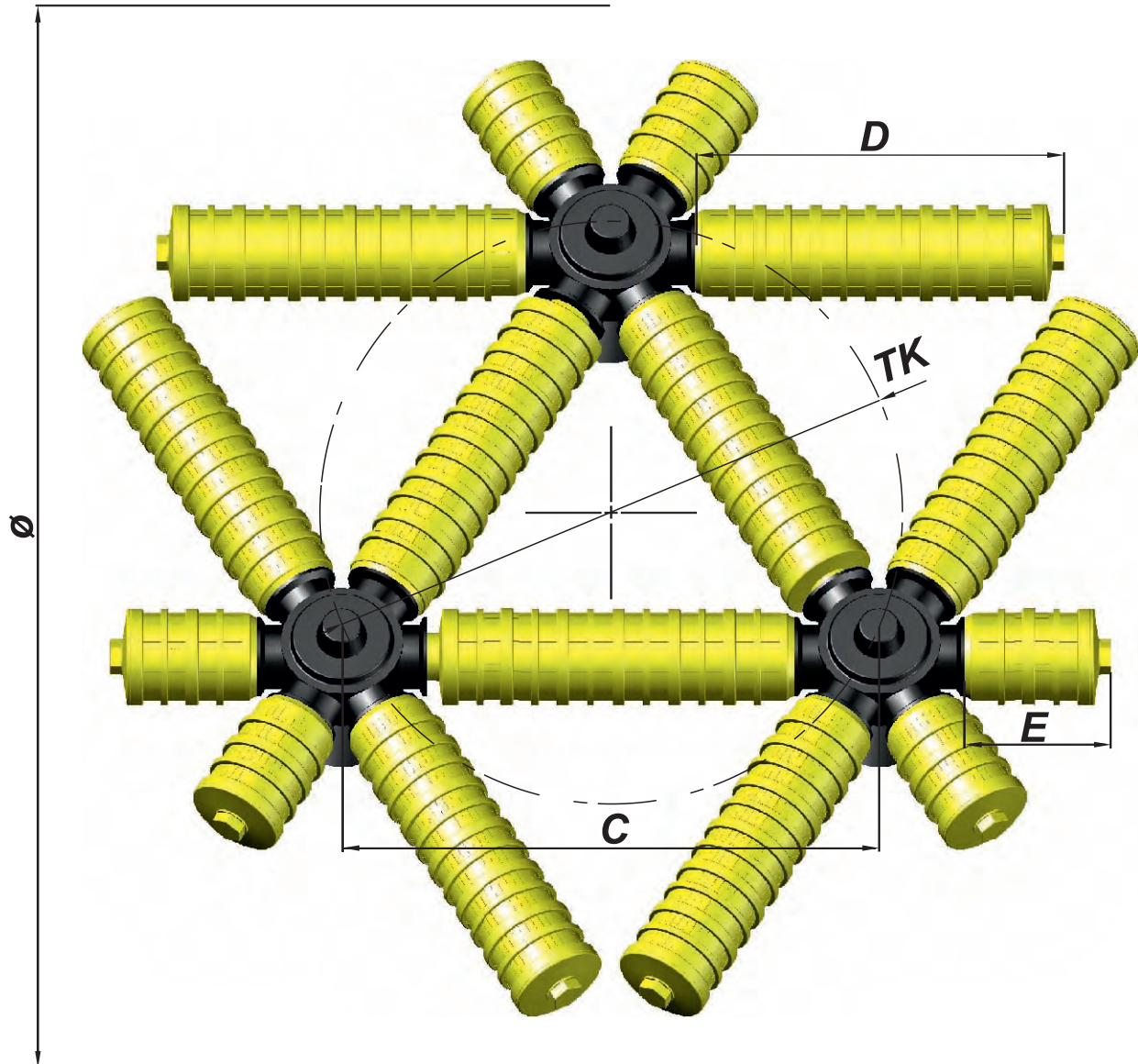

Bestellung Ordering Commande Encargo	Typ Type Type Tipa	Schlitze Slots Fentes Ranuras	Ø	TK	C	D	E
✉	SD3	0,2 0,5	600	308	265	175	82
			700	344	298	206	82
			800	416	362	268	144
			900	452	392	299	144
			1000	522	454	361	175
			1100	522	454	361	237
			1200	522	454	361	299

Drainage-
system

Drainage
system

Système de
drainage

Systema de
drenaje

Typ SD6

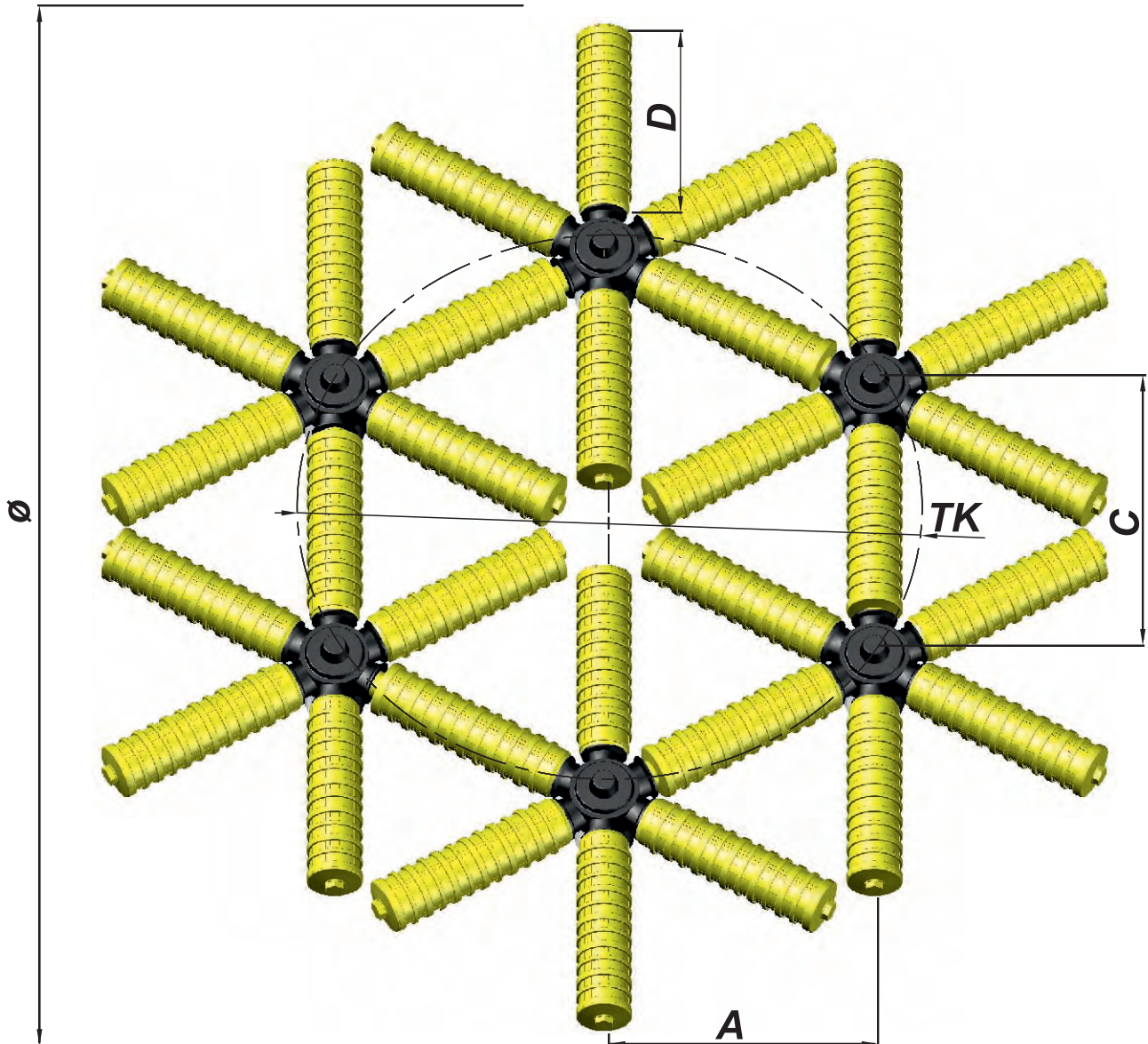

Bestellung Ordering Commande Encargo	Typ Type Type Tipa	Schlitze Slots Fentes Ranuras	\varnothing	TK	C	D	A
✉	SD6	0,2	800	408	204	113	176,7
			1000	536	268	175	232,1
			1200	600	300	206	259,8
			1300	664	332	237	287,5
		0,5	1400	728	364	268	315,2
			1500	788	394	299	341,2
			1700	852	426	330	368,9
			1800	912	456	361	394,9

**Filterdüsen-Sterne
mit 6 Armen**

**Filter-Nozzles-Stars
with 6 arms**

**Crépines
étoiles
à 6 bras**

**Estrellas para
toberas a filtro
con 6 brazos**

Typ SS6

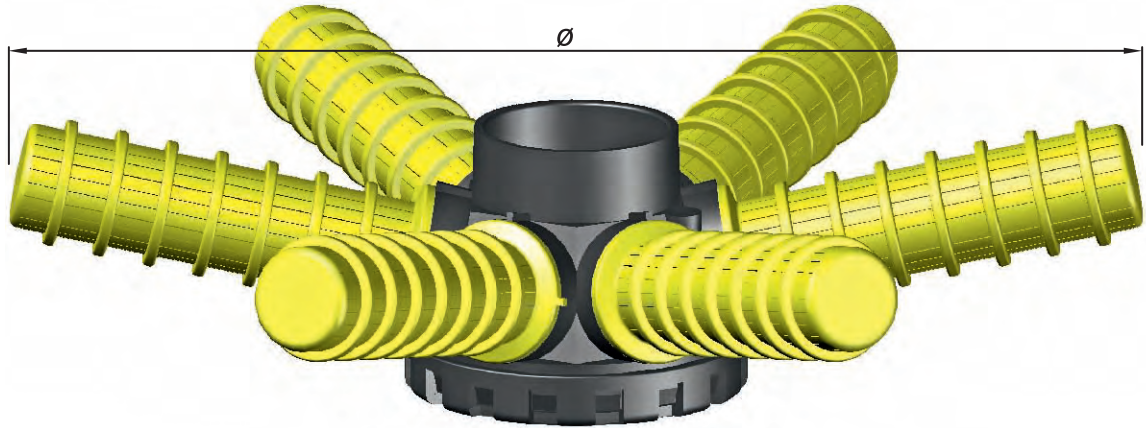

Typ MSS6

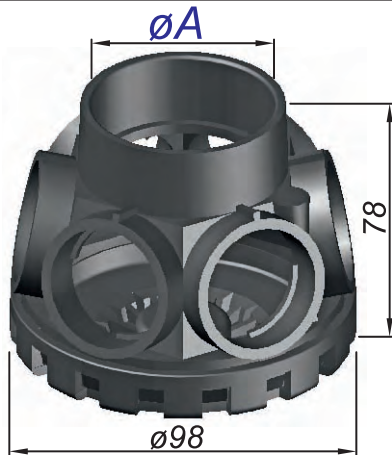

Bestellung Ordering Commande Encargo	Typ Type Type Tipa	ØA	Material Material Materiau Material
	MSS6	ø 1.05" ø 1" ø 1¼" ø 1.9" ø 50	ABS

Typ A4

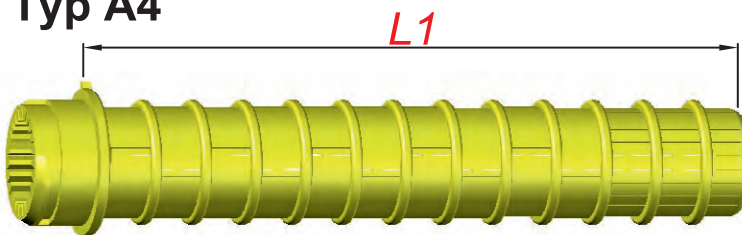

Bestellung Ordering Commande Encargo	Typ Type Type Tipa	Schlitze Slots Fentes Ranuras	L1	= Ø
	A4	0,25	143 = Ø	373
			185 = Ø	460
			210 = Ø	510
		teilweise geschlossen partially closed		

Typ A5

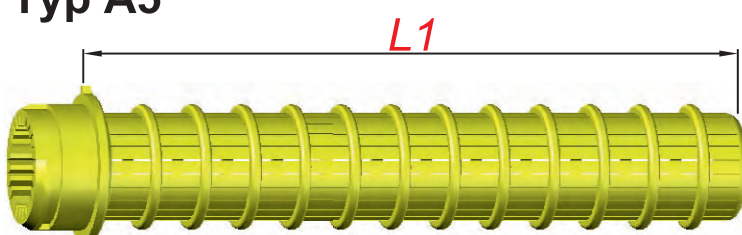

Bestellung Ordering Commande Encargo	Typ Type Type Tipa	Schlitze Slots Fentes Ranuras	L1	= Ø
	A5	0,25	85 = Ø	260
			113 = Ø	314
			143 = Ø	373
			185 = Ø	460
			210 = Ø	510

Filterdüsen-Sterne
mit 8 Armen

Filter-Nozzles-Stars
with 8 arms

Crépines étoiles
à 8 bras

Estrellas para
toberas a filtro
con 8 brazos

Typ SS8

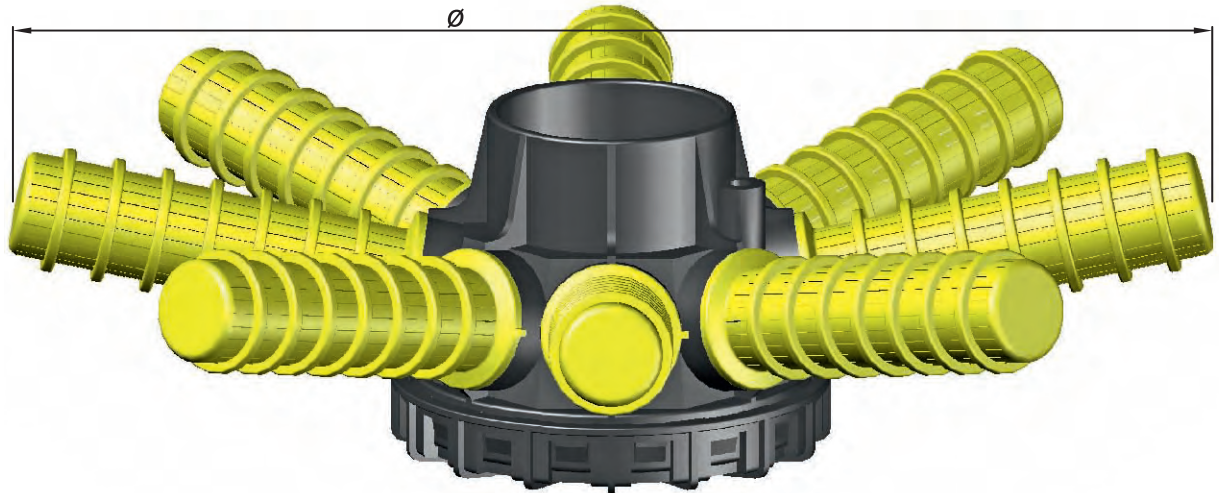

Typ MSS8

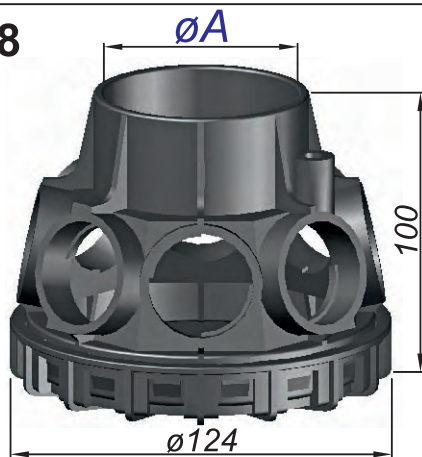

Bestellung Ordering Commande Encargo	Typ Type Type Tipa	ø A	Material Material Materiau Material
	MSS8	ø 60,3 ø 63	ABS

Typ A4

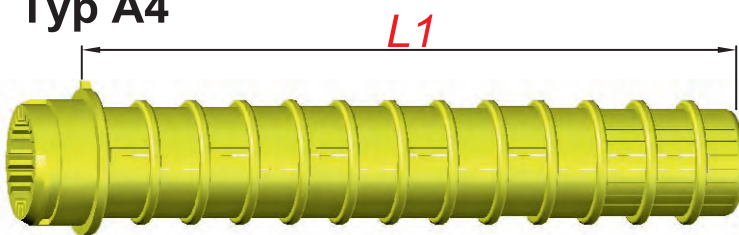

Bestellung Ordering Commande Encargo	Typ Type Type Tipa	Schlitz Slots Fentes Ranuras	L1	= ø
	A4	0,25	143	= ø 397
			185	= ø 479
			210	= ø 532
		teilweise geschlossen partially closed		

Typ A5

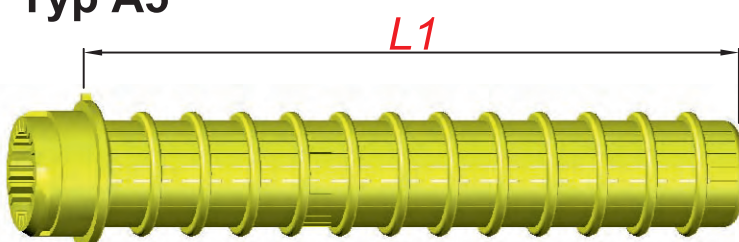

Bestellung Ordering Commande Encargo	Typ Type Type Tipa	Schlitz Slots Fentes Ranuras	L1	= ø
	A5	0,25	85	= ø 284
			113	= ø 338
			143	= ø 397
			185	= ø 479
			210	= ø 532
			240	= ø 586
			270	= ø 644
			312	= ø 726

Filterdüsen-
Arme

Filter-Nozzles
Arms

Crépines bras

Brazos de toberas
a filtro

Typ SSR

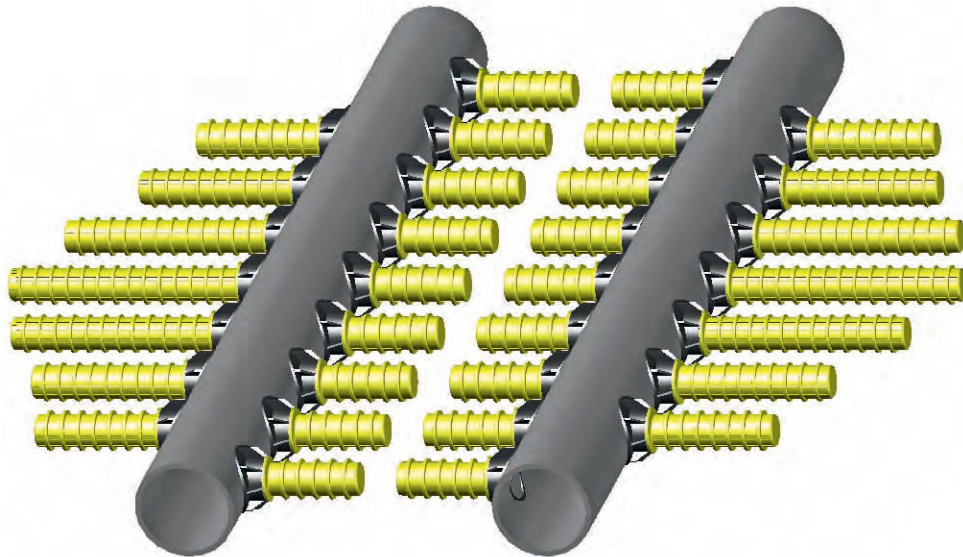

Typ SSR

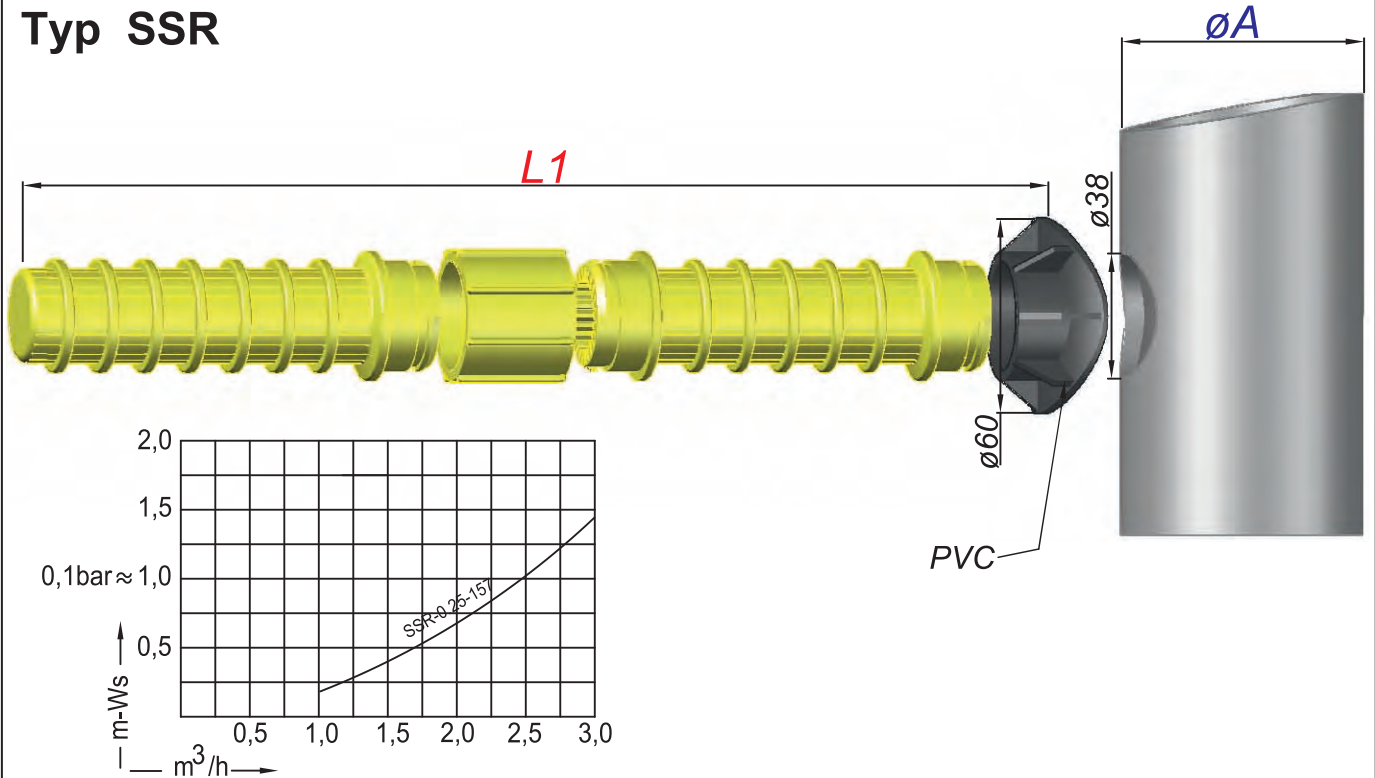

Bestellung Ordering Commande Encargo	Typ Type Type Tipa	Schlitz Slots Fentes Ranuras	øA	Länge Length Longueur Largura
	SSR	0,25	ø63 ø75 ø90 ø114	L1
				99, 127, 157, 199, 224, 254, 284, 326, 351, 381, 411, 453, 480, 508, 538, 580, 607, 635, 665, 707, 734, 762, 792, 834, 861, 889, 919, 961, 988, 1016, 1046, 1088 ...

Filterdüsen-
Arme

Filter-Nozzles
Arms

Crépines bras

Brazos de toberas
a filtro

Typ A3

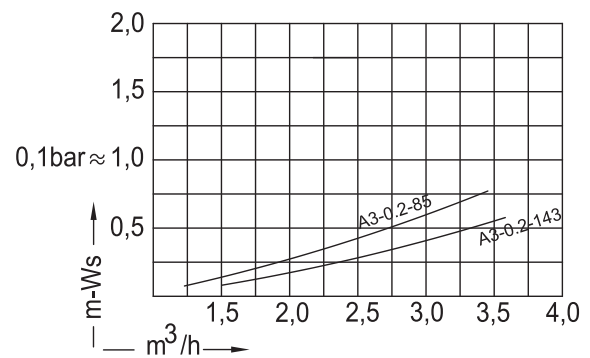
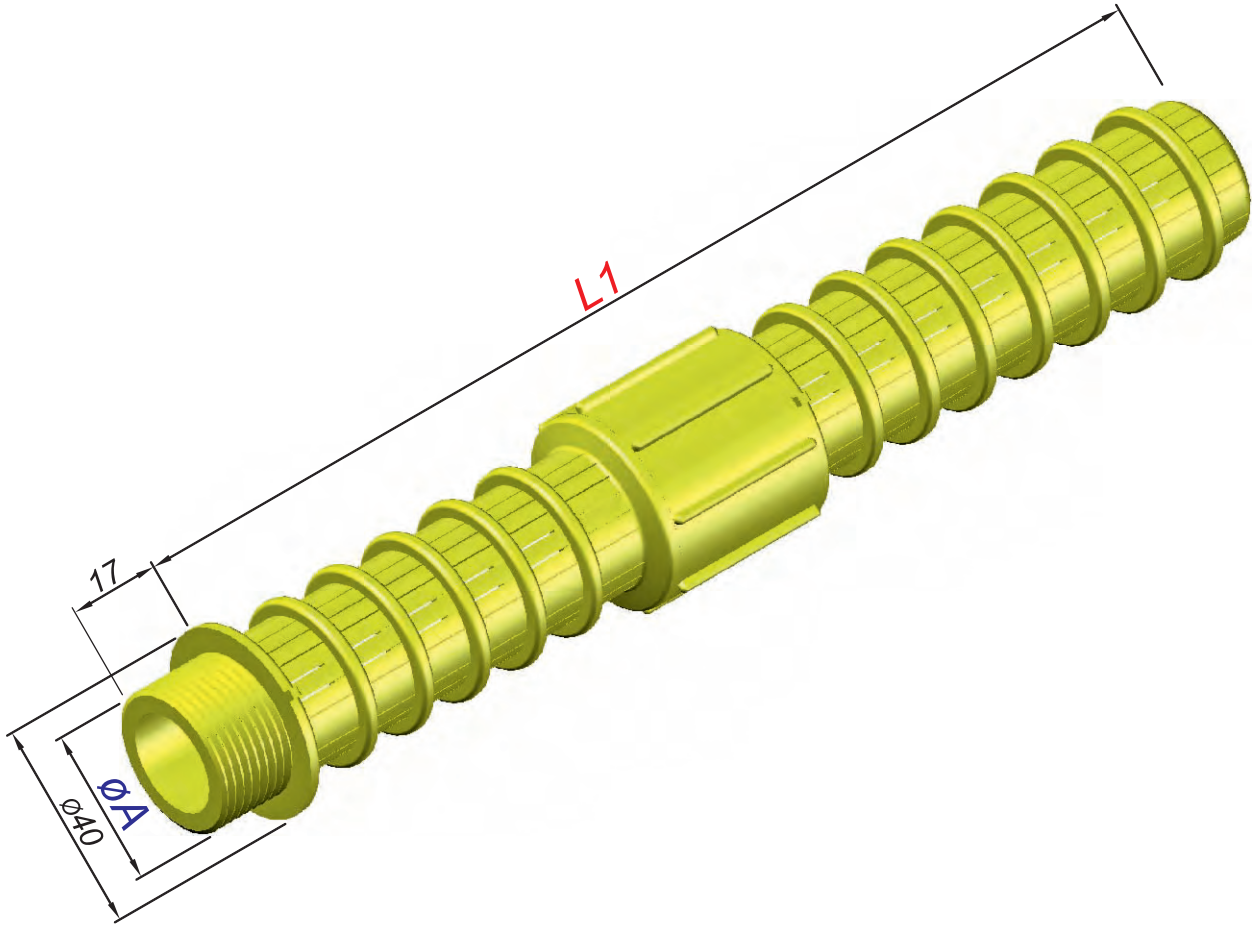

Bestellung Ordering Commande Encargo	Type Type Type Tipa	Schlitze Slots Fentes Ranuras	Gewinde Thread Filetage Rosca	øA	Länge Length Longueur Largura	L1
✉	A3	0,25	G 3/4"		212, 240, 270, 312, 337, 367, 397, 439, 464, 494, 524, 566, 591, 621, 651, 693, 820, 947, 1074, ...	
			M30x2			
			G 1"		85, 113, 143, 185, 210, 240, 270, 312, 337, 367, 397, 439, 464, 494, 524, 566, 591, 621, 651, 693, 820, 947, 1074, ...	

Typ HSD

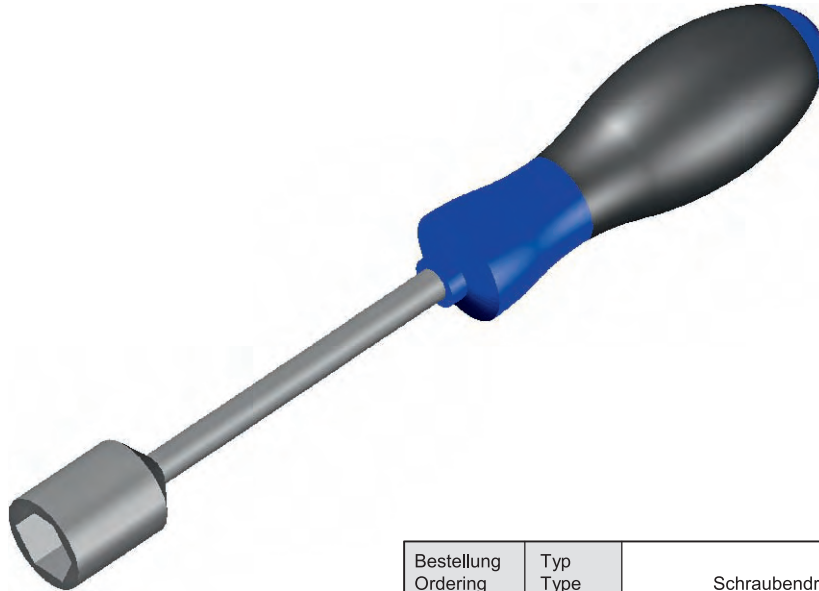

Bestellung Ordering Commande Encargo	Typ Type Type Tipa	Schraubendreher Screwdriver
	HSD	SW17

Typ DSD

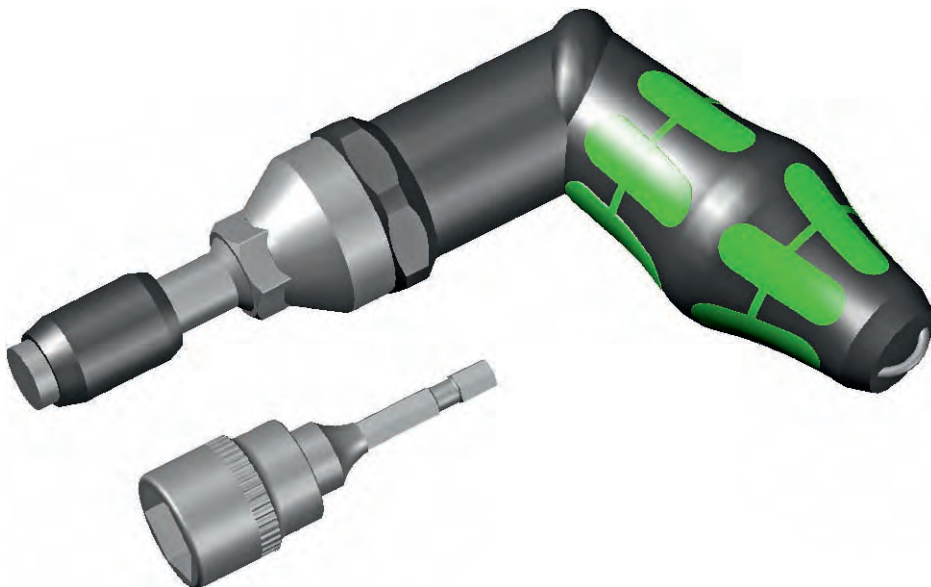

Bestellung Ordering Commande Encargo	Typ Type Type Tipa	Drehmoment - Schraubendreher Torque screwdriver Tournevis à déclenchement Atornillador con limitador de par
	DSD	SW17 3-6 Nm

Beispiele
Sonderanfertigungen
auf Anfrage
Zum Download:
www.ksh-filter.de

Examples for
special-design
on request
For Download:
www.ksh-filter.de

Exemples de
fabrication spéciale
sur demande
Pour Télécharger:
www.ksh-filter.de

Ejemplos de
fabricaciones especial
sobre demanda
Para Descargar:
www.ksh-filter.de

DSR

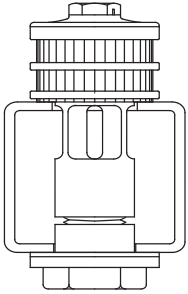

KE

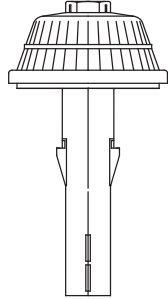

R2DB

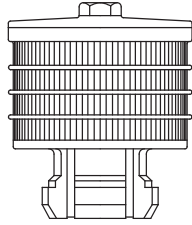

G2

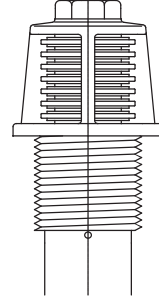

KSPB

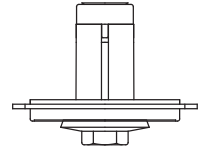

LB

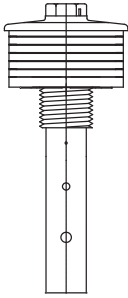

LB2

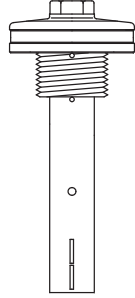

MST



RSP

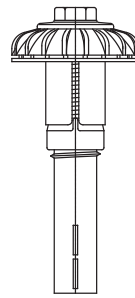

MV

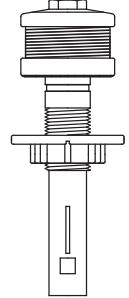

S2DB

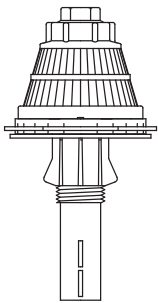

S2GR

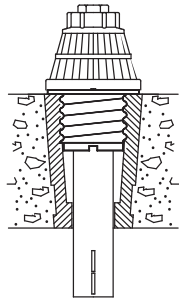

CA

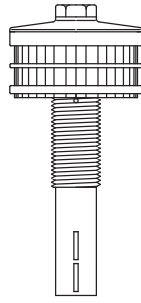

SLR

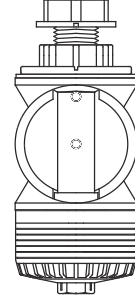

DD

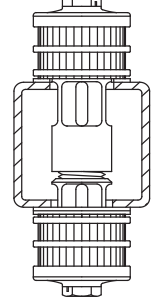

SCR

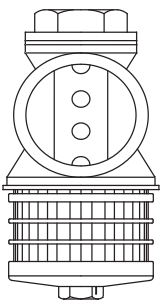

VP

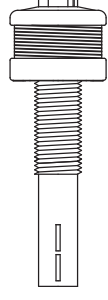

S2/S2

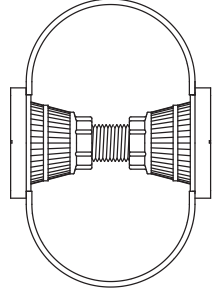

Lanzen

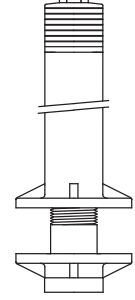

LCR

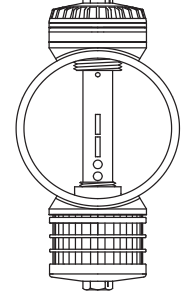

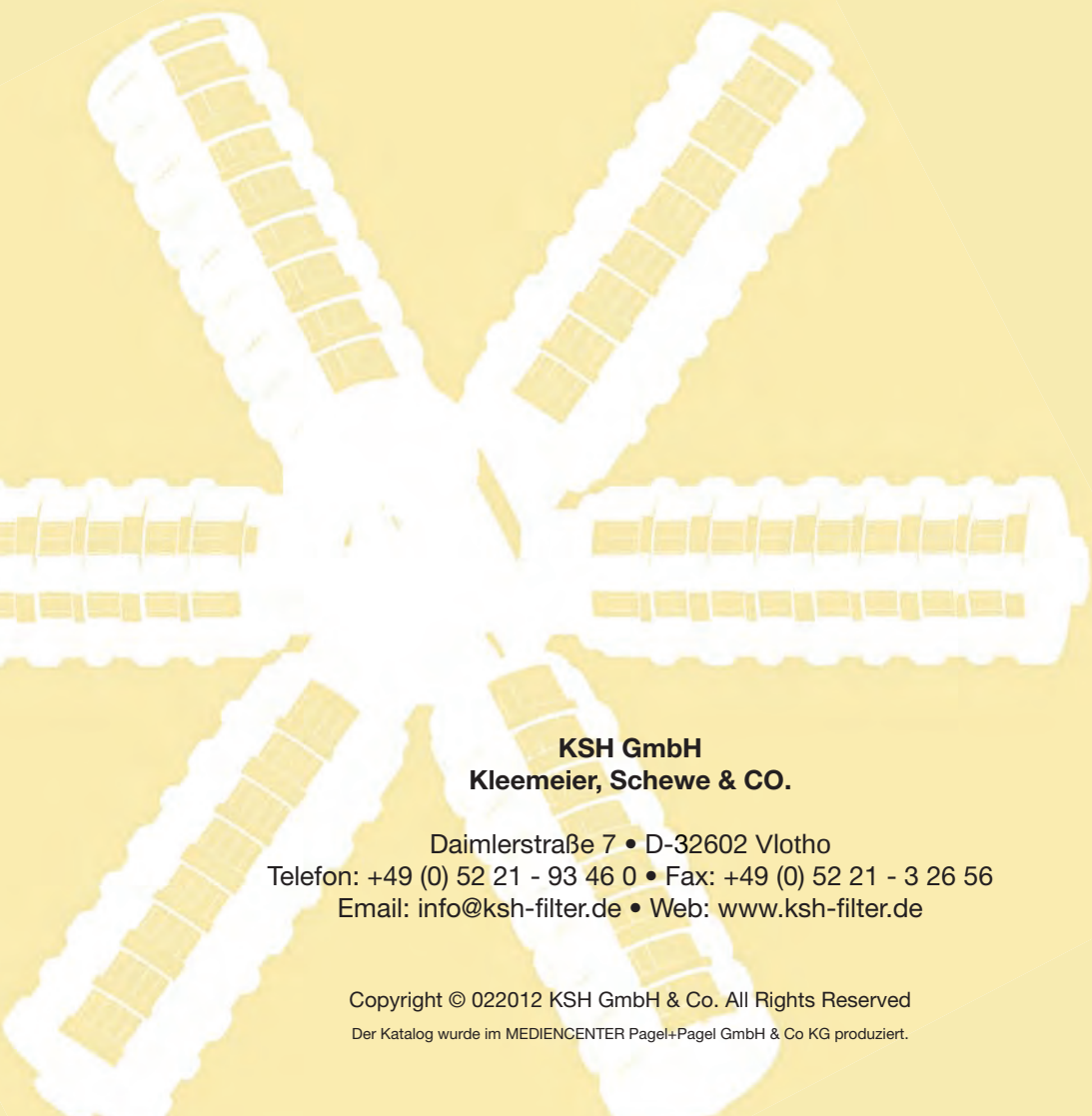
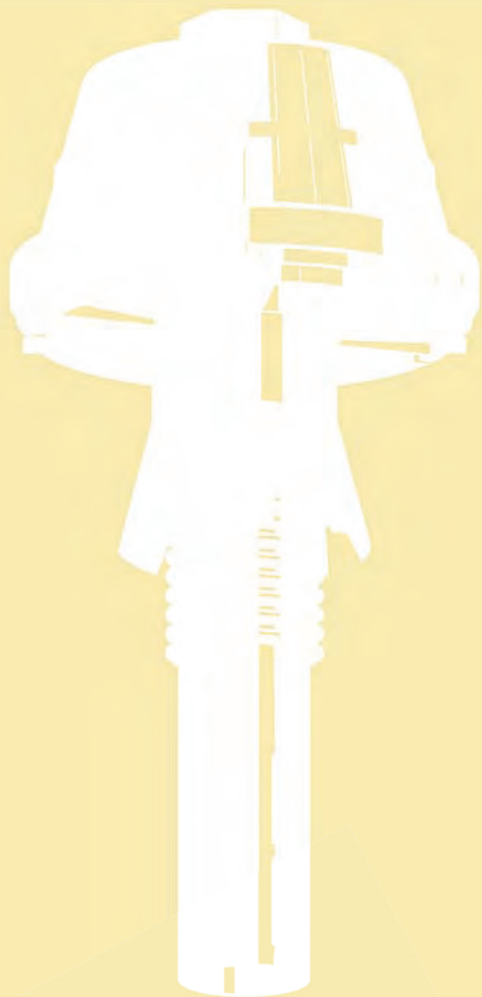

KSH GmbH
Kleemeier, Schewe & CO.

Daimlerstraße 7 • D-32602 Vlotho
Telefon: +49 (0) 52 21 - 93 46 0 • Fax: +49 (0) 52 21 - 3 26 56
Email: info@ksh-filter.de • Web: www.ksh-filter.de

Copyright © 022012 KSH GmbH & Co. All Rights Reserved
Der Katalog wurde im MEDIENCENTER Pagel+Pagel GmbH & Co KG produziert.

